

МИНИСТЕРСТВО ОБРАЗОВАНИЯ РЕСПУБЛИКИ БЕЛАРУСЬ

**УЧРЕЖДЕНИЕ ОБРАЗОВАНИЯ
«БРЕСТСКИЙ ГОСУДАРСТВЕННЫЙ ТЕХНИЧЕСКИЙ УНИВЕРСИТЕТ»**

Кафедра высшей математики

**FUNCTIONS OF SEVERAL VARIABLES
INTEGRALS**

for foreign first-year students

**учебно-методическая разработка на английском языке
по дисциплине «Математика»
для студентов 1-го курса**

Брест 2014

Настоящая методическая разработка предназначена для иностранных студентов первого курса технических специальностей. Данная разработка содержит необходимый материал по разделам «Функции нескольких переменных», «Неопределенный интеграл», «Определенный интеграл и его приложения», «Несобственный интеграл» курса «Математики», который изучается студентами на первом курсе. Изложение теоретического материала по всем темам сопровождается рассмотрением большого количества примеров и задач, некоторые понятия и примеры проиллюстрированы. Изложение материала ведется на доступном, по возможности строгом языке.

Составители: Гладкий И.И., доцент

Дворниченко А.В., старший преподаватель

Дерачиц Н.А., старший преподаватель

Каримова Т.И., к.ф.-м.н., доцент

Шишко Т.В., преподаватель кафедры иностранных языков по техническим специальностям

Рецензент: Мирская Е.И., доцент кафедры математического моделирования учреждения образования «Брестский государственный университет им. А.С. Пушкина», к.ф.-м.н., доцент

I FUNCTIONS OF SEVERAL VARIABLES

Functions of two variables can be visualized by means of level curves, which connect points where the function takes on a given value. In the real world, physical quantities often depend on two or more variables, so in this chapter we turn our attention to functions of several variables and extend the basic ideas of differential calculus to such functions.

1.1 Functions of Two Variables

Definition. A **function of two variables** is a rule that assigns to each ordered pair of real numbers (x,y) in a set D a unique real number denoted by $f(x,y)$. The set D is the **domain** of f and its **range** is the set of values that f takes on, that is $\{f(x,y) | (x,y) \in D\}$.

We often write $z = f(x,y)$ to make explicit the value taken on by f at the general point (x,y) . The variables x and y are **independent variables** and z is the **dependent variable**. [Compare this with the notation $y = f(x)$ for functions of a single variable.]

A function of two variables is just a function whose domain is a subset of \mathbf{R}^2 and whose range is a subset of \mathbf{R} . One way of visualizing such a function is by means of an arrow diagram (see Figure 1), where the domain D is represented as a subset of the xy -plane.

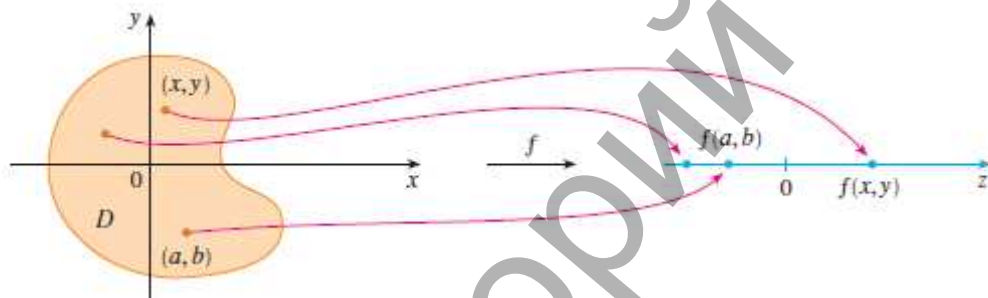

Figure 1

If a function f is given by a formula and no domain is specified, then the domain of f is understood to be the set of all pairs for which the given expression is a well-defined real number.

Definition. If f is a function of two variables with domain D , then the **graph** of f is the set of all points (x,y,z) in \mathbf{R}^3 such that $z = f(x,y)$ and (x,y) is in D .

Just as the graph of a function f of one variable is a curve C with equation $y = f(x)$ so the graph of a function f of two variables is a surface S with equation $z = f(x,y)$. We can visualize the graph S of f as lying directly above or below its domain D in the xy -plane (See Figure 2).

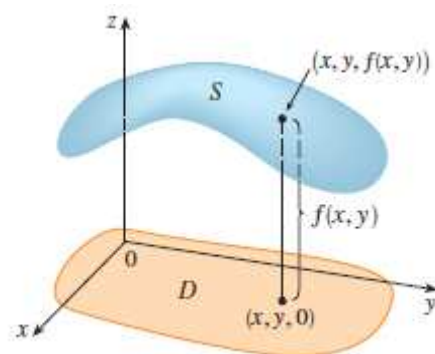

Figure 2

So far we have two methods for visualizing functions: arrow diagrams and graphs. A third method, borrowed from mapmakers, is a contour map on which points of constant elevation are joined to form *contour curves*, or *level curves*.

Definition. The **level curves** of a function f of two variables are the curves with equations $f(x,y) = k$, where k is a constant (in the range of f).

A level curve $f(x,y) = k$ is the set of all points in the domain of f at which f takes on a given value k . In other words, it shows where the graph of f has height k . You can see from Figure 3 the relation between level curves and horizontal traces. The level curves $f(x,y) = k$ are just the traces of the graph of f in the horizontal plane $z = k$ projected down to the xy -plane. So if you draw the level curves of a function and visualize them being lifted up to the surface at the indicated height, then you can mentally piece together a picture of the graph. The surface is steep where the level curves are close together. It is somewhat flatter where they are farther apart.

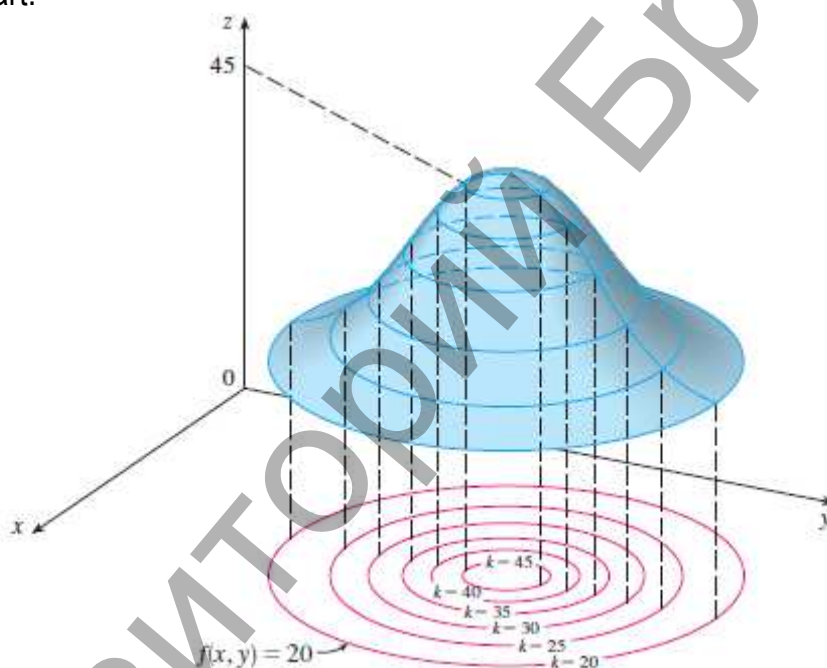

Figure 3

Example 1. Find the domain and range of $z = \sqrt{9 - x^2 - y^2}$. Sketch the graph of $z = \sqrt{9 - x^2 - y^2}$.

Solution. The domain of z is $D = \{(x,y) \mid 9 - x^2 - y^2 \geq 0\} = \{(x,y) \mid x^2 + y^2 \leq 9\}$ which is the disk with center $(0,0)$ and radius 3 (See Figure 4.)

The graph has equation $z = \sqrt{9 - x^2 - y^2}$. We square both sides of this equation to obtain $z^2 = 9 - x^2 - y^2$, or $x^2 + y^2 + z^2 = 9$, which we recognize as an equation of the sphere with center the origin and radius 3. But, since $z \geq 0$, the graph of z is just the top half of this sphere (see Figure 5).

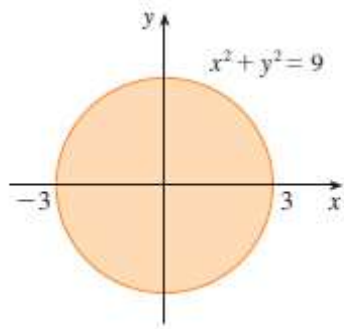

Figure 4

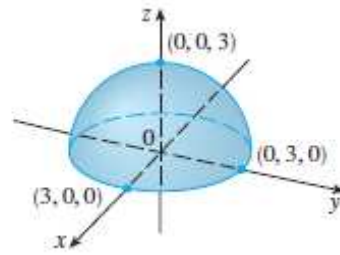

Figure 5

Functions of any number of variables can be considered. A **function of n variables** is a rule that assigns a number $z = f(x_1, x_2, \dots, x_n)$ to an n -tuple (x_1, x_2, \dots, x_n) of real numbers. We denote \mathbf{R}^n by the set of all such n -tuples. For example, if a company uses n different ingredients in making a food product, c_i is the cost per unit of the ingredient, and x_i units of the i -th ingredient are used, then the total cost C of the ingredients is a function of the n variables x_1, x_2, \dots, x_n :

$$C = f(x_1, x_2, \dots, x_n) = c_1x_1 + c_2x_2 + \dots + c_nx_n$$

Exercise Set 1

Find and sketch the domain of the function.

1. $z = \sqrt{y^2 - 2x + 4}$.

2. $z = \ln x + \ln \cos y$.

3. $z = \sqrt{x^2 - 4} + \sqrt{4 - y^2}$.

4. $z = \sqrt{x^2 - 3y + 4}$.

5. $z = \ln(x + y)$.

6. $z = \sqrt{x^2 - 9} + \sqrt{25 - y^2}$.

1.2 Partial Derivatives

Definition. Let f be a function of two variables whose domain D includes points arbitrarily close to (a, b) . Then we say that the **limit of $f(x, y)$ as (x, y) approaches (a, b)** is L and we write

$$\lim_{(x,y) \rightarrow (a,b)} f(x,y) = L$$

if for every number $\epsilon > 0$ there is a corresponding number $\delta > 0$ such that if $(x, y) \in D$ and $0 < \sqrt{(x-a)^2 + (y-b)^2} < \delta$ then $|f(x, y) - L| < \epsilon$.

Other notations for the limit in Definition are

$$\lim_{\substack{x \rightarrow a \\ y \rightarrow b}} f(x,y) = L \text{ and } f(x,y) \rightarrow L \text{ as } (x,y) \rightarrow (a,b).$$

Definition. A function f of two variables is called **continuous at (a, b)** if

$$\lim_{(x,y) \rightarrow (a,b)} f(x,y) = f(a,b).$$

We say f is **continuous on D** if f is continuous at every point in (a, b) .

The intuitive meaning of continuity is that if the point (x, y) changes by a small amount, then the value of $f(x, y)$ changes by a small amount. This means that a surface that is the graph of a continuous function has no hole or break.

Using the properties of limits, you can see that sums, differences, products, and quotients of continuous functions are continuous on their domains.

If f is a function of two variables x and y , suppose we let only x vary while keeping y fixed, say $y = b$, where b is a constant. Then we are really considering a function of a single variable x , namely $g(x) = f(x, b)$. If g has a derivative at a , then we call it the **partial derivative of f with respect to x at (a, b)** and denote it by $f'_x(a, b)$.

Thus $f'_x(a, b) = g'(a)$.

By the definition of a derivative, we have

$$\lim_{Dx \rightarrow 0} \frac{D_x z}{Dx} = \lim_{Dx \rightarrow 0} \frac{f(x + Dx; y) - f(x; y)}{Dx} = \frac{\partial z}{\partial x} = z'_x = f'_x(x, y).$$

Similarly, the **partial derivative of f with respect to y at (a, b)** , denoted by $f'_y(a, b)$, is obtained by keeping x fixed ($x = a$) and finding the ordinary derivative at b of the function $f(a, y)$:

$$\lim_{Dy \rightarrow 0} \frac{D_y z}{Dy} = \lim_{Dy \rightarrow 0} \frac{f(x; y + Dy) - f(x; y)}{Dy} = \frac{\partial z}{\partial y} = z'_y = f'_y(x, y).$$

Rule for Finding Partial Derivatives of $z = f(x, y)$

1. To find $f'_x(x, y)$, regard y as a constant and differentiate $f(x, y)$ with respect to x .
2. To find $f'_y(x, y)$, regard x as a constant and differentiate $f(x, y)$ with respect to y .

Partial derivatives can also be defined for functions of three or more variables.

Example 1. Find $f'_x(x, y)$, $f'_y(x, y)$ if $z = f(x, y) = 2x^3 + 3x^2y + 6xy - y^3$.

Solution. $f'_x = 6x^2 + 6xy + 6y - 0 = 6(x^2 + xy + y)$;

$$f'_y = 0 + 3x^2 + 6x - 3y^2 = 3(x^2 + 2xy - y^2).$$

Example 2. Find $f'_x(x, y, z)$, $f'_y(x, y, z)$ and $f'_z(x, y, z)$ if $f(x, y, z) = \frac{x}{y} + \frac{y}{z} + \frac{z}{x}$.

$$\text{Solution. } f'_x = \frac{\partial f}{\partial x} = \frac{1}{y} + \frac{z}{x^2};$$

$$f'_y = \frac{\partial f}{\partial y} = -\frac{x}{y^2} + \frac{1}{z};$$

$$f'_z = \frac{\partial f}{\partial z} = -\frac{y}{z^2} - \frac{1}{x}.$$

Interpretations of Partial Derivatives

To give a geometric interpretation of partial derivatives, we recall that the equation $z = f(x, y)$ represents a surface S (the graph of f). If $f(a, b) = c$, then the point $P(a, b, c)$ lies on S . By fixing $y = b$, we are restricting our attention to the curve C_1 in which the vertical plane $y = b$ intersects S . (In other words, C_1 is the trace of S in the plane $y = b$). Likewise,

the vertical plane $x = a$ intersects S in a curve C_2 . Both of the curves C_1 and C_2 pass through the point P . (See Figure 6.)

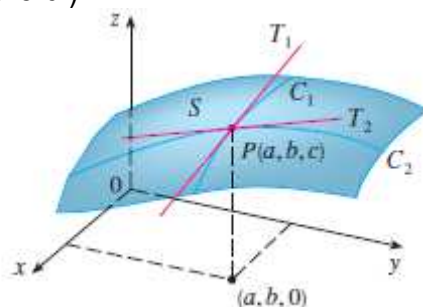

Figure 6

Thus the partial derivatives $f'_x(a,b)$ and $f'_y(a,b)$ can be interpreted geometrically as the slopes of the tangent lines at $P(a,b,c)$ to the traces C_1 and C_2 of in the planes $y = b$ and $x = a$.

Directional Derivatives and the Gradient Vector

Definition. The **directional derivative** of $u = f(x,y,z)$ at $M_0(x_0,y_0,z_0)$ in the direction of a vector $\vec{a} = (l,m,n)$ is

$$\lim_{M \rightarrow M_0} \frac{Du(M_0)}{|M_0M|} = \frac{\partial u(M_0)}{\partial a}, \quad \vec{a} = \vec{M_0M}$$

if this limit exists.

This derivative is found by the formula

$$\frac{\partial u(M_0)}{\partial a} = u'_x(M_0) \cdot \cos a + u'_y(M_0) \cdot \cos b + u'_z(M_0) \cdot \cos g,$$

$$\cos a = \frac{l}{|\vec{a}|}, \quad \cos b = \frac{m}{|\vec{a}|}, \quad \cos g = \frac{n}{|\vec{a}|}.$$

Directional derivative shows the rate of change in the function at the particular point in this direction.

Definition. If f is a function of two variables x and y , then the **gradient** of f is the vector function defined by

$$\nabla f(x,y) = \text{grad } f = (f'_x, f'_y).$$

Derivative in the direction of its gradient takes maximum value.

Example 2. Find the directional derivative of the function $u = x + y^2 - z^3$ at the given point $M_0(1;2;-1)$ in the direction of the vector $\vec{a} = (2;-6;3)$. Find the gradient of $u(x,y,z)$.

Solution. We find particular derivatives at the point of M_0 .

$$u'_x = 1, \quad u'_x(1, 2, -1) = 1.$$

$$u'_y = 2y, \quad u'_y(1, 2, -1) = 2 \cdot 2 = 4.$$

$$u'_z = -3z^2, \quad u'_z(1, 2, -1) = -3 \cdot (-1)^2 = -3.$$

$$|\vec{a}| = \sqrt{2^2 + (-6)^2 + 3^2} = \sqrt{4 + 36 + 9} = \sqrt{49} = 7.$$

$$\cos a = \frac{2}{|a|} = \frac{2}{7}.$$

$$\cos b = \frac{-6}{|a|} = -\frac{6}{7}.$$

$$\cos g = \frac{3}{|a|} = \frac{3}{7}.$$

Then the desired derivative is equal

$$\frac{\partial u(M_0)}{\partial a} = 1 \cdot \frac{2}{7} + 4 \cdot \left(-\frac{6}{7}\right) - 3 \cdot \frac{3}{7} = \frac{2 - 24 - 9}{7} = -\frac{31}{7}.$$

$$\nabla u(x, y, z) = \text{gradu} = (u'_x, u'_y, u'_z) = (1, 2y, -3z^2).$$

Tangent Planes

The equation $z = f(x, y)$ represents a surface S (the graph of f). If $f(x_0, y_0) = z_0$, then the point $P(x_0, y_0, z_0)$ lies on S . By fixing $y = y_0$, we are restricting our attention to the curve C_1 in which the vertical plane $y = y_0$ intersects S . (In other words, C_1 is the trace of S in the plane $y = y_0$). Likewise, the vertical plane $x = x_0$ intersects S in a curve C_2 . Both of the curves C_1 and C_2 pass through the point P . Let T_1 and T_2 be the tangent lines to the curves C_1 and C_2 at the point $P(x_0, y_0, z_0)$. Then the **tangent plane** to the surface S at the point $P(x_0, y_0, z_0)$ is defined to be the plane that contains both tangent lines T_1 and T_2 . (See Figure 7)

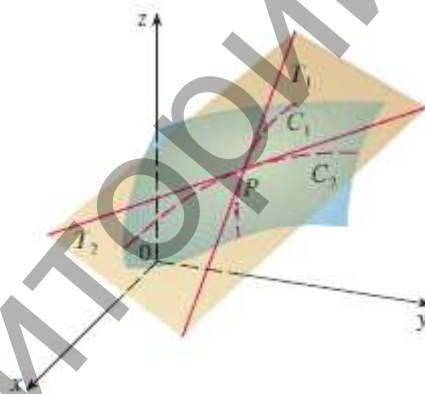

Figure 7

Suppose f has continuous partial derivatives. An equation of the tangent plane to the surface $z = f(x, y)$ at the point $P(x_0, y_0, z_0)$ is

$$z - z_0 = f'_x(x_0, y_0) \cdot (x - x_0) + f'_y(x_0, y_0) \cdot (y - y_0).$$

The canonical equations of normal to this surface, carried out through the point $P(x_0, y_0, z_0)$ will be written down thus

$$\frac{x - x_0}{f'_x(x_0, y_0)} = \frac{y - y_0}{f'_y(x_0, y_0)} = \frac{z - z_0}{-1}.$$

Note. Again the gradient vector gives the direction of fastest increase of f . Also, by considerations similar to our discussion of tangent planes, it can be shown that $\text{grad} f = \nabla f(x_0, y_0)$ is perpendicular to the level curve $f(x, y) = k$ that passes through $P(x_0, y_0, z_0)$. Again this is intuitively plausible because the values of f remain constant as we move along the curve. (See Figure 8.)

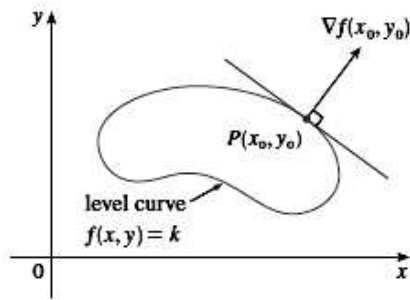

Figure 8

Example 1. Find the tangent plane to the elliptic paraboloid $z = 2x^2 + y^2$ at the point $P(1;1;3)$.

Solution. Let $z = 2x^2 + y^2$. Then

$$\begin{aligned} f'_x(x, y) &= 4x, & f'_x(1, 1) &= 4; \\ f'_y(x, y) &= 2y, & f'_y(1, 1) &= 2. \end{aligned}$$

Then $z - z_0 = f'_x(x_0, y_0) \cdot (x - x_0) + f'_y(x_0, y_0) \cdot (y - y_0)$ gives the equation of the tangent plane at $P(1;1;3)$ as

$$z - 3 = 4(x - 1) + 2(y - 1)$$

or

$$z = 4x + 2y - 3.$$

Exercise Set 2

To find the particular derivatives

1. $z(x, y) = 3x^3 y^2 + 2x^2 y - 4xy^3 + 5x - 15y^2 + 3$.
2. $z(x, y) = 4y^3 x^2 - 5y^2 x + 3yx^3 + 3y - 5x^2 + 7$.
3. $z(x, y) = 2x^3 y^2 - 2x^3 y - 4xy^3 + 5x - 2y^3 + 7$.
4. $z(x, y) = 7y^3 x^2 + 3y^2 x - yx^3 + 3y^2 - 5x^2 + 1$.
5. $z(x, y) = 5x^3 y^2 - 3x^2 y + 2xy^3 - 4x + 8y^2 - 4$.
6. $z(x, y) = 2y^3 x^2 - 4y^2 x + 3yx^3 - 5y + 7x^2 - 6$.
7. $z(x, y) = 3x^2 y^3 - 5x^2 y + 2xy^3 + y - 4x + 7y^2 - 11$.
8. $z(x, y) = 3y^3 x^2 + 5y^2 x + 2yx^3 - 7y^2 + 2x - 12$.
9. $z(x, y) = 7x^3 y^2 - 4x^2 y - 7xy^3 + 2y^2 - 2x - 5$.
10. $z(x, y) = 2x^3 y^2 - 3xy + 2xy^3 - 4x^2 + 4y - 5$.

Find the directional derivative of the function $f(x, y)$ at the given point M_0 in the direction of the vector \vec{a} . Find the gradient of $f(x, y)$.

11. $z(x, y) = x^3 - 2y^2 x + xy + 3y^2 - x - 3y + 3$, $M(-1;3)$, $\vec{a} = (12; -5)$.
12. $z(x, y) = x^2 + xy + y^2 + 2x + 2y$, $M(1;1)$, $\vec{a} = (3;4)$.
13. $z(x, y) = 2y^3 - 2x^2 y + 2xy^2 - 5$, $M(-2;1)$, $\vec{a} = (-4;3)$.
14. $z(x, y) = -3y^3 - 4x^2 y - 6xy^2 + 5$, $M(-1;2)$, $\vec{a} = (-8; -6)$.

Find an equation of the tangent plane to the given surface at the specified point.

15. $S: z = x^2 + 2y^2 + 4xy - 5y - 10$, $M_1(-7; 1; 8)$.
16. $S: z = 4y^2 + 4xy - x$, $M_1(1; -2; 7)$.
17. $S: z = x^2 - y^2 - 4x + 2y$, $M_1(3; 1; -2)$.
18. $S: z = x^2 + y^2 - 4xy + 3x - 15$, $M_1(-1; 3; 4)$.

1.3 Differentials. The Chain Rule

For a differentiable function of two variables $z = f(x, y)$, we define the **differentials** dx and dy to be independent variables; that is, they can be given any values. Then the **differential** dz , also called the **total differential**, is defined by

$$dz = z'_x dx + z'_y dy = f'_x(x, y) dx + f'_y(x, y) dy, \quad Dx = dx, \quad Dy = dy.$$

Sometimes the notation df is used in place of dz .

The **differential** du is defined in terms of the differentials dx , dy and dz of the independent variables by

$$u = f(x, y, z) \quad du = f'_x(x, y, z) dx + f'_y(x, y, z) dy + f'_z(x, y, z) dz.$$

Figure 9 shows the geometric interpretation of the differential dz and the increment Dz represents the change in height of the tangent plane, whereas Dz represents the change in height of the surface $z = f(x, y)$ when (x, y) changes from (a, b) to $(a + Dx, b + Dy)$.

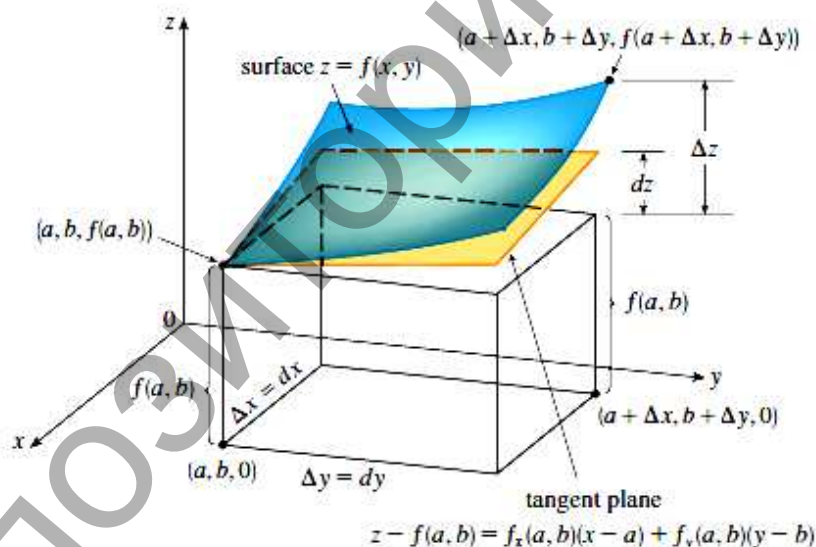

Figure 9

If we take $x = x_0 + Dx$ and $y = y_0 + Dy$ in $dz = z'_x dx + z'_y dy = f'_x(x, y) dx + f'_y(x, y) dy$, then the differential of z is

$$dz = f'_x(x, y)(x - x_0) + f'_y(x, y)(y - y_0).$$

So, in the notation of differentials, the linear approximation can be written as

$$f(x; y) \approx f(x_0; y_0) + f'_x(x_0; y_0) \cdot Dx + f'_y(x_0; y_0) \cdot Dy.$$

Example 1. Calculate $\sqrt{4,11^2 + 3,02^2}$.

Solution. $\sqrt{4,11^2 + 3,02^2} = \sqrt{(4 + 0,11)^2 + (3 + 0,02)^2}$.

Let $f(x;y) = \sqrt{x^2 + y^2}$ where $x = x_0 + Dx$; $x_0 = 4$; $Dx = 0,11$;
 $y = y_0 + Dy$; $y_0 = 3$; $Dy = 0,02$.
 $f(x_0;y_0) = \sqrt{4^2 + 3^2} = 5$.

$$f'_x(x;y) = \left(\sqrt{x^2 + y^2}\right)' = \frac{x}{\sqrt{x^2 + y^2}}; \quad f'_x(x_0;y_0) = \frac{3}{\sqrt{3^2 + 4^2}} = \frac{3}{5}.$$

$$f'_y(x;y) = \left(\sqrt{x^2 + y^2}\right)' = \frac{y}{\sqrt{x^2 + y^2}}; \quad f'_y(x_0;y_0) = \frac{4}{\sqrt{3^2 + 4^2}} = \frac{4}{5}.$$

$$f(x;y) \approx f(x_0;y_0) + f'_x(x_0;y_0) \cdot Dx + f'_y(x_0;y_0) \cdot Dy.$$

$$\sqrt{4,11^2 + 3,02^2} \approx 5 + 0,6 \cdot 0,11 + 0,8 \cdot 0,02 = 5 + 0,066 + 0,016 = 5,082.$$

Example 2. Find the differential of the function $z(x,y) = \operatorname{tg}^5 \sqrt{\frac{y}{x}}$.

Solution.

$$z'_x = \left(\operatorname{tg}^5 \sqrt{\frac{y}{x}}\right)'_x = 5\operatorname{tg}^4 \sqrt{\frac{y}{x}} \cdot \left(\operatorname{tg} \sqrt{\frac{y}{x}}\right)'_x = 5\operatorname{tg}^4 \sqrt{\frac{y}{x}} \cdot \frac{1}{\cos^2 \sqrt{\frac{y}{x}}} \cdot \left(\sqrt{\frac{y}{x}}\right)'_x =$$

$$= 5\operatorname{tg}^4 \sqrt{\frac{y}{x}} \cdot \frac{1}{\cos^2 \sqrt{\frac{y}{x}}} \cdot \sqrt{y} \cdot \left(\frac{1}{\sqrt{x}}\right)'_x = 5\operatorname{tg}^4 \sqrt{\frac{y}{x}} \cdot \frac{1}{\cos^2 \sqrt{\frac{y}{x}}} \cdot \sqrt{y} \cdot \left(-\frac{1}{2}x^{-\frac{3}{2}}\right) =$$

$$= -5\operatorname{tg}^4 \sqrt{\frac{y}{x}} \cdot \frac{1}{\cos^2 \sqrt{\frac{y}{x}}} \cdot \frac{\sqrt{y}}{2x\sqrt{x}}.$$

$$z'_y = \left(\operatorname{tg}^5 \sqrt{\frac{y}{x}}\right)'_y = 5\operatorname{tg}^4 \sqrt{\frac{y}{x}} \cdot \left(\operatorname{tg} \sqrt{\frac{y}{x}}\right)'_y = 5\operatorname{tg}^4 \sqrt{\frac{y}{x}} \cdot \frac{1}{\cos^2 \sqrt{\frac{y}{x}}} \cdot \left(\sqrt{\frac{y}{x}}\right)'_y =$$

$$= 5\operatorname{tg}^4 \sqrt{\frac{y}{x}} \cdot \frac{1}{\cos^2 \sqrt{\frac{y}{x}}} \cdot \frac{1}{\sqrt{x}} \cdot (\sqrt{y})'_y = 5\operatorname{tg}^4 \sqrt{\frac{y}{x}} \cdot \frac{1}{\cos^2 \sqrt{\frac{y}{x}}} \cdot \frac{1}{\sqrt{x}} \cdot \left(\frac{1}{2}y^{-\frac{1}{2}}\right) =$$

$$= 5\operatorname{tg}^4 \sqrt{\frac{y}{x}} \cdot \frac{1}{\cos^2 \sqrt{\frac{y}{x}}} \cdot \frac{1}{2\sqrt{xy}}.$$

$$dz = z'_x dx + z'_y dy = -5\operatorname{tg}^4 \sqrt{\frac{y}{x}} \cdot \frac{1}{\cos^2 \sqrt{\frac{y}{x}}} \cdot \frac{\sqrt{y}}{2x\sqrt{x}} dx + 5\operatorname{tg}^4 \sqrt{\frac{y}{x}} \cdot \frac{1}{\cos^2 \sqrt{\frac{y}{x}}} \cdot \frac{1}{2\sqrt{xy}} dy.$$

For functions of more than one variable, the Chain Rule has several versions, each of them giving a rule for differentiating a composite function. The first version deals with the case where $z = f(u,v)$ and each of the variables u and v is, in turn, a function of a variable x . This means that z is indirectly a function of x , $z = f(u(x),v(x))$ and the Chain Rule gives a formula for differentiating z as a function of x . We assume that is differentiable.

The Chain Rule (Case 1)

Suppose that $z = f(u,v)$ is a differentiable function of u and v , where $u = f(x)$, $v = y(x)$, and are both differentiable functions of x .

Then z is a differentiable function of x and

$$\frac{dz}{dx} = \frac{\partial z}{\partial u} \cdot \frac{du}{dx} + \frac{\partial z}{\partial v} \cdot \frac{dv}{dx}.$$

The Chain Rule (Case 2)

Suppose that $z = f(u,v)$ is a differentiable function of u and v , where $u = f(x,y)$ and $v = y(x,y)$ are differentiable functions of x and y . Then

$$\begin{cases} z'_x = z'_u \cdot u'_x + z'_v \cdot v'_x, \\ z'_y = z'_u \cdot u'_y + z'_v \cdot v'_y. \end{cases}$$

Implicit Differentiation

The Chain Rule can be used to give a more complete description of the process of implicit differentiation. We suppose that an equation of the form $F(x,y) = 0$ defines implicitly as a differentiable function of x , that is, $y = f(x)$, where $F(x,f(x)) = 0$ for all x in the domain of f . If F is differentiable, we can apply Case 1 of the Chain Rule to differentiate both sides of the equation $F(x,y) = 0$ with respect to x . Since both x and y are functions of x , we obtain

$$\frac{dy}{dx} = -\frac{F'_x(x,y)}{F'_y(x,y)}.$$

Now we suppose that is given implicitly as a function $z = f(x,y)$ by an equation of the form $F(x,y,z) = 0$. This means that $F(x,y,f(x,y)) = 0$ for all (x,y) in the domain of f . If F and f are differentiable, then we can use the Chain Rule to differentiate the equation $F(x,y,z) = 0$ as follows:

$$\frac{\partial z}{\partial x} = -\frac{F'_x(x,y,z)}{F'_z(x,y,z)}, \quad \frac{\partial z}{\partial y} = -\frac{F'_y(x,y,z)}{F'_z(x,y,z)}.$$

Note. Suppose f has continuous partial derivatives. An equation of the tangent plane to the surface $F(x,y,z) = 0$ at the point $P_0(x_0,y_0,z_0)$ is

$$F'_x(x_0,y_0,z_0) \cdot (x-x_0) + F'_y(x_0,y_0,z_0) \cdot (y-y_0) + F'_z(x_0,y_0,z_0) \cdot (z-z_0) = 0.$$

The canonical equations of normal to this surface, carried out through the point $P_0(x_0,y_0,z_0)$ will be written down thus

$$\frac{x-x_0}{F'_x(P_0)} = \frac{y-y_0}{F'_y(P_0)} = \frac{z-z_0}{F'_z(P_0)}.$$

Example 3. Find the differential of the function $z = \frac{x^2}{y}$ if $x = u - 2v$, $y = 2u + v$.

Solution. $dz = \frac{\partial z}{\partial u} du + \frac{\partial z}{\partial v} dv$.

$$\frac{\partial z}{\partial u} = \frac{2x}{y} \cdot 1 + \left(-\frac{1}{y^2}\right) \cdot x^2 \cdot 2 = \frac{2x}{y} - \frac{2x^2}{y^2}.$$

$$\frac{\partial z}{\partial v} = \frac{2x}{y} \cdot (-2) + \left(-\frac{1x^2}{y^2}\right) \cdot 1 = -\frac{4x}{y} - \frac{x^2}{y^2}.$$

$$\begin{aligned} dz &= \left(\frac{2x}{y} - \frac{2x^2}{y^2}\right) du + \left(-\frac{4x}{y} - \frac{x^2}{y^2}\right) dv = \frac{x}{y} \left[2 \left(1 - \frac{x}{y}\right) du - \left(4 - \frac{x}{y}\right) dv \right] = \\ &= \frac{u-2v}{2u+v} \left[2 \left(1 - \frac{u-2v}{2u+v}\right) du - \left(4 + \frac{u-2v}{2u+v}\right) dv \right] = \\ &= \frac{u-2v}{(2u+v)^2} [2(u+3v)du - (9u+2v)dv]. \end{aligned}$$

Example 4. Find the particular derivatives $4x^2 + 2y^2 - 3z^2 + xy - yz + x - 4 = 0$.

Solution. $F(x; y; z) = 4x^2 + 2y^2 - 3z^2 + xy - yz + x - 4$.

$$F'_x = (4x^2 + 2y^2 - 3z^2 + xy - yz + x - 4)'_x = 8x + y + 1.$$

$$F'_y = (4x^2 + 2y^2 - 3z^2 + xy - yz + x - 4)'_y = 4y + x - z.$$

$$F'_z = (4x^2 + 2y^2 - 3z^2 + xy - yz + x - 4)'_z = -6z - y.$$

$$\frac{\partial z}{\partial x} = -\frac{F'_x}{F'_z} = \frac{8x + y + 1}{6z + y}; \quad \frac{\partial z}{\partial y} = -\frac{F'_y}{F'_z} = \frac{x + 4y - z}{6z + y}.$$

Exercise Set 3

Find the differential of the function

1. $z(x, y) = \arccos^3 \sqrt{\frac{y}{x}}$.

6. $z(x, y) = \arcsin^5 \sqrt{\frac{y}{x}}$.

2. $z(x, y) = \text{arctg}^6 \sqrt{\frac{x}{y}}$.

7. $z(x, y) = \text{arcctg}^4 \sqrt{\frac{x}{y}}$.

3. $z(x, y) = \sin^3 \frac{\sqrt{y}}{x^4}$.

8. $z(x, y) = \cos^5 \frac{\sqrt{x}}{y^3}$.

4. $z(x, y) = \text{ctg}^4 \frac{y^5}{\sqrt{x}}$.

9. $z(x, y) = \text{tg}^3 \frac{x^4}{\sqrt{y}}$.

5. $z(x, y) = \cos^2 \left(\frac{x^2}{y}\right)$.

10. $z(x, y) = \sin^3 \left(\frac{x}{y^2}\right)$.

Find the particular derivatives

$$11. \quad z = f(u, v), \quad u = x^2 - 4\sqrt{y}, \quad v = xe^y.$$

$$12. \quad z = \arccos \frac{u}{v}, \quad u = x + \ln y, \quad v = -2e^{-x^2}.$$

$$13. \quad z = f(u, v), \quad u = xy + \frac{y}{x}, \quad v = x^3 - y^2.$$

$$14. \quad z = e^{u^2 - 3\sin v}, \quad u = x \cos y, \quad v = \frac{x}{y}.$$

Calculate

$$15. \quad \sqrt{3,12^2 + 3,98^2}.$$

$$16. \quad \sqrt{5,86^2 + 8,11^2}.$$

$$17. \quad \sqrt{5,19^2 + 11,97^2}.$$

$$18. \quad \sqrt{3,03^2 + 3,87^2}.$$

$$19. \quad \sqrt{6,12^2 + 7,98^2}.$$

$$20. \quad \sqrt{5,13^2 + 11,91^2}.$$

1.4 Higher Derivatives. Maximum and Minimum Values

If f is a function of two variables, then its partial derivatives $f'_x(x, y)$ and $f'_y(x, y)$ are also functions of two variables, so we can consider their partial derivatives $(f'_x)'_x$, $(f'_x)'_y$, $(f'_y)'_x$, and $(f'_y)'_y$, which are called the **second partial derivatives** of f . If $z = f(x, y)$, we use the following notation:

$$\begin{aligned} \frac{\partial}{\partial x} \left(\frac{\partial z}{\partial x} \right) &= \frac{\partial^2 z}{\partial x^2} = (z'_x)'_x = z''_{xx}, & \frac{\partial}{\partial y} \left(\frac{\partial z}{\partial x} \right) &= \frac{\partial^2 z}{\partial x \partial y} = (z'_x)'_y = z''_{xy}, \\ \frac{\partial}{\partial x} \left(\frac{\partial z}{\partial y} \right) &= \frac{\partial^2 z}{\partial y \partial x} = (z'_y)'_x = z''_{yx}, & \frac{\partial}{\partial y} \left(\frac{\partial z}{\partial y} \right) &= \frac{\partial^2 z}{\partial y^2} = (z'_y)'_y = z''_{yy}. \end{aligned}$$

Thus the notation $f''_{xy}(x; y)$ (or $\frac{\partial^2 z}{\partial x \partial y}$) means that we first differentiate with respect to x and then with respect to y , whereas in computing $f''_{yx}(x; y)$ the order is reversed.

Example 1. Find the second partial derivatives of $z = x^3 + 2x^2y - 8xy^2 + y^3$.

Solution. $z'_x = 3x^2 + 4xy - 8y^2$ and $z'_y = 2x^2 - 16xy + 3y^2$.

$$z''_{xx} = (3x^2 + 4xy - 8y^2)'_x = 6x + 4y.$$

$$z''_{xy} = (3x^2 + 4xy - 8y^2)'_y = 4x - 16y.$$

$$z''_{yx} = (2x^2 - 16xy + 3y^2)'_x = 4x - 16y.$$

$$z''_{yy} = (2x^2 - 16xy + 3y^2)'_y = -16x + 6y.$$

Notice that in *Example 1* $z''_{xy} = z''_{yx}$. This is not just a coincidence. It turns out that the mixed partial derivatives z''_{xy} and z''_{yx} are equal for most functions that one meets in practice. The following theorem, which was discovered by the French mathematician Alexis Clairaut (1713–1765), gives conditions under which we can assert that $z''_{xy} = z''_{yx}$.

Clairaut's Theorem. Suppose z is defined on a disk D that contains the point (a,b) . If the functions z''_{xy} and z''_{yx} are both continuous on D , then $z''_{xy}(a,b) = z''_{yx}(a,b)$.

Partial derivatives of order 3 or higher can also be defined. For instance,

$$z'''_{xyy} = (z''_{xy})'_y = \frac{\partial}{\partial y} \left(\frac{\partial^2 z}{\partial y \partial x} \right).$$

Then the **differential** d^2z of $z = f(x,y)$, also called the **total differential order by two**, is defined by

$$d^2z = \frac{\partial^2 z}{\partial x^2} \cdot dx^2 + 2 \frac{\partial^2 z}{\partial x \partial y} \cdot dx dy + \frac{\partial^2 z}{\partial y^2} \cdot dy^2.$$

One of the main uses of ordinary derivatives is in finding maximum and minimum values. In this section we see how to use partial derivatives to locate maxima and minima of functions of two variables.

Look at the hills and valleys in the graph of f shown in Figure 10. There are two points (a,b) where f has a *local maximum*, that is, where $f(a,b)$ is larger than nearby values of $z = f(x,y)$. The larger of these two values is the *absolute maximum*. Likewise, f has two *local minima*, where $f(a,b)$ is smaller than nearby values. The smaller of these two values is the *absolute minimum*.

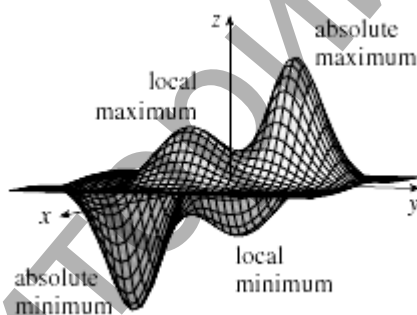

Figure 10

Definition. A function f of two variables has a **local maximum** at (a,b) if $f(x,y) \leq f(a,b)$ when (x,y) is near (a,b) . [This means that $f(x,y) \leq f(a,b)$ for all points (x,y) in some disk with center (a,b) .] The number $f(a,b)$ is called a **local maximum value**. If $f(x,y) \geq f(a,b)$ when (x,y) is near (a,b) , then f has a **local minimum** at (a,b) and $f(a,b)$ is a **local minimum value**.

If the inequalities in Definition hold for *all* points (x,y) in the domain of f , then f has an **absolute maximum** (or **absolute minimum**) at (a,b) .

Theorem. If f has a local maximum or minimum at (a,b) and the first-order partial derivatives of f exist there, then $f'_x(a,b) = 0$ $f'_y(a,b) = 0$.

Thus the geometric interpretation of Theorem is that if the graph of f has a tangent plane at a local maximum or minimum, then the tangent plane must be horizontal.

A point (a,b) is called a **critical point** (or *stationary point*) of f if $f'_x(a,b) = 0$ and $f'_y(a,b) = 0$, or if one of these partial derivatives does not exist. Theorem says that if f has a

local maximum or minimum at (a,b) , then (a,b) is a critical point of f . However, as in single-variable calculus, not all critical points give rise to maxima or minima. At a critical point, a function could have a local maximum or a local minimum or neither.

We need to be able to determine whether or not a function has an extreme value at a critical point. The following test, which is proved at the end of this section, is analogous to the Second Derivative Test for functions of one variable.

Second Derivatives Test. Suppose the second partial derivatives of u are continuous on a disk with center (x_0, y_0) , and suppose that (x_0, y_0) is a critical point of u . Let

$$D = \begin{vmatrix} u''_{xx}(x_0, y_0) & u''_{xy}(x_0, y_0) \\ u''_{yx}(x_0, y_0) & u''_{yy}(x_0, y_0) \end{vmatrix}.$$

(a) If $D > 0$ and $u''_{xx}(x_0, y_0) > 0$, then $u(x_0, y_0)$ is a local minimum.

(b) If $D > 0$ and $u''_{xx}(x_0, y_0) < 0$, then $u(x_0, y_0)$ is a local maximum.

(c) If $D > 0$, then $u(x_0, y_0)$ is not a local maximum or minimum.

Note 1. In case (c) the point (x_0, y_0) is called a **saddle point** of u and the graph of u crosses its tangent plane at (x_0, y_0) .

Note 2. If $D = 0$, the test gives no information: u could have a local maximum or local minimum at (x_0, y_0) , or (x_0, y_0) could be a saddle point of u .

Example 2. Find the local maximum and minimum values and saddle points of

$$z(x, y) = 2x^3 - 12xy + 3y^2 - 18x - 6y + 3.$$

Solution. We first locate the critical points:

$$z'_x = (2x^3 - 12xy + 3y^2 - 18x - 6y + 3)'_x = 6x^2 - 12y - 18;$$

$$z'_y = (2x^3 - 12xy + 3y^2 - 18x - 6y + 3)'_y = -12x + 6y - 6.$$

Setting these partial derivatives equal to 0, we obtain the equations

$$\begin{cases} z'_x = 0, \\ z'_y = 0. \end{cases}$$

$$\begin{cases} 6x^2 - 12y - 18 = 0, \\ -12x + 6y - 6 = 0, \end{cases} \Leftrightarrow \begin{cases} x^2 - 2y - 3 = 0, \\ -2x + y - 1 = 0. \end{cases} \Leftrightarrow \begin{cases} x^2 - 2(2x + 1) - 3 = 0, \\ y = 2x + 1, \end{cases} \Leftrightarrow \begin{cases} x^2 - 4x - 5 = 0, \\ y = 2x + 1. \end{cases}$$

$$x = \frac{4 \pm \sqrt{(-4)^2 - 4 \cdot (-5)}}{2} = \frac{4 \pm \sqrt{16 + 20}}{2} = \frac{4 \pm \sqrt{36}}{2} = \frac{4 \pm 6}{2}$$

$$\begin{cases} x = \frac{4-6}{2} = -1, \\ y = 2 \cdot (-1) + 1 = -1, \end{cases} \quad \text{or} \quad \begin{cases} x = \frac{4+6}{2} = 5, \\ y = 2 \cdot 5 + 1 = 11. \end{cases}$$

The two critical points are $M_1(-1; -1)$ and $M_2(5; 11)$.

Next we calculate the second partial derivatives and D :

$$z''_{xx} = (z'_x)'_x = (6x^2 - 12y - 18)'_x = 6(x^2)'_x - 0 - 0 = 12x;$$

$$z''_{xy} = (z'_x)'_y = (6x^2 - 12y - 18)'_y = 0 - 12(y)'_y - 0 = -12;$$

$$z''_{yx} = (z'_y)'_x = (-12x + 6y - 6)'_x = -12(x)'_x + 0 - 0 = -12;$$

$$z''_{yy} = (z'_y)'_y = (-12x + 6y - 6)'_y = 0 + 6(y)'_y - 0 = 6.$$

$$D = \begin{vmatrix} z''_{xx} & z''_{xy} \\ z''_{yx} & z''_{yy} \end{vmatrix} = z''_{xx} \cdot z''_{yy} - z''_{xy} \cdot z''_{yx} = 12x \cdot 6 - (-12) \cdot (-12) = 72x - 144.$$

Since $D(M_1(-1,-1)) = 72 \cdot (-1) - 144 = -216 < 0$ it follows from case (c) of the Second Derivatives Test that the point $M_1(-1,-1)$ is a saddle point; that is, $z(x,y)$ has no local maximum or minimum at $M_1(-1,-1)$.

Since $D(M_2(5,11)) = 72 \cdot 5 - 144 = 216 > 0$ and $z''_{xx}(M_2) = z''_{xx}(5;11) = 12 \cdot 5 = 60 > 0$ we see from case (a) of the test that

$$z_{\min}(x;y) = z(5;11) = -200 \text{ is a local minimum.}$$

Example 3. Find the local maximum and minimum values and saddle points of

$$z(x,y) = x^4 + y^4 - 4xy + 1.$$

Solution. We first locate the critical points:

$$z'_x = (x^4 + y^4 - 4xy + 1)'_x = 4x^3 - 4y;$$

$$z'_y = (x^4 + y^4 - 4xy + 1)'_y = 4y^3 - 4x.$$

Setting these partial derivatives equal to 0, we obtain the equations

$$x^3 - y = 0 \text{ and } y^3 - x = 0.$$

To solve these equations we substitute $y = x^3$ from the first equation into the second one. This gives

$$0 = x^9 - x = x(x^8 - 1) = x(x^4 - 1)(x^4 + 1) = x(x^2 - 1)(x^2 + 1)(x^4 + 1)$$

so there are three real roots: 0, -1, 1. The three critical points are $M_1(0,0)$, $M_2(-1,-1)$ and $M_3(1,1)$.

Next we calculate the second partial derivatives and D :

$$z''_{xx} = (z'_x)'_x = 12x^2;$$

$$z''_{xy} = (z'_x)'_y = z''_{yx} = -4;$$

$$z''_{yy} = (z'_y)'_y = 12y^2.$$

$$D = \begin{vmatrix} z''_{xx} & z''_{xy} \\ z''_{yx} & z''_{yy} \end{vmatrix} = z''_{xx} \cdot z''_{yy} - z''_{xy} \cdot z''_{yx} = 144x^2y^2 - 16.$$

Since $D(M_1(0,0)) = -16 < 0$ it follows from case (c) of the Second Derivatives Test that the point $M_1(0,0)$ is a saddle point; that is, $z(x,y)$ has no local maximum or minimum at $M_1(0,0)$.

Since $D(M_2(-1,-1)) = 144 - 16 = 128 > 0$ and $z''_{xx}(M_2) = z''_{xx}(-1,-1) = 12 \cdot 1 = 12 > 0$ we see from case (a) of the test that

$$z_{\min}(x;y) = z(-1,-1) = -1 \text{ is a local minimum.}$$

Since $D(M_3(1,1)) = 144 - 16 = 128 > 0$ and $z''_{xx}(M_3) = z''_{xx}(1,1) = 12 \cdot 1 = 12 > 0$ we see from case (a) of the test that

$$z_{\min}(x;y) = z(1,1) = -1 \text{ is a local minimum.}$$

The graph of z is shown in Figure 11.

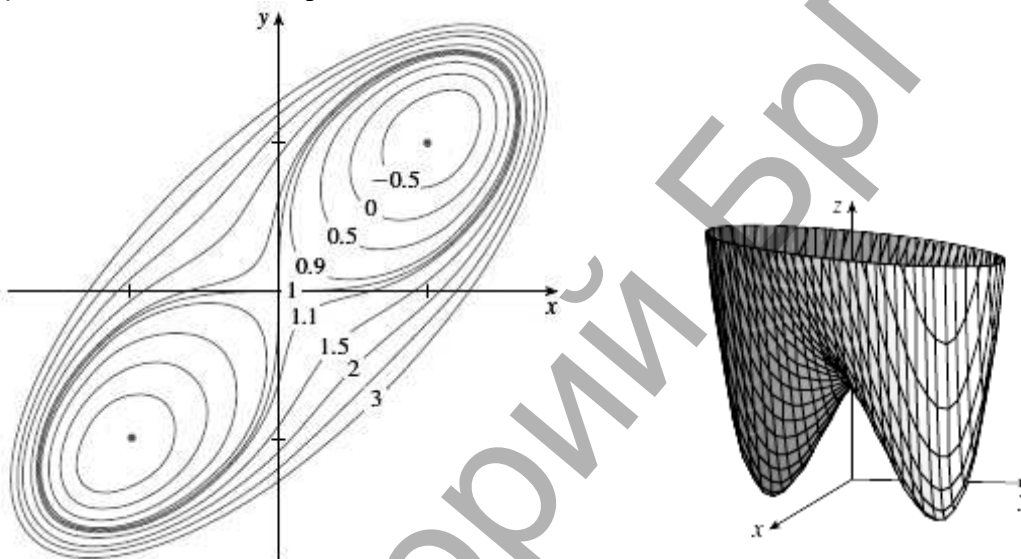

Figure 11

Absolute Maximum and Minimum Values

For a function of f one variable the Extreme Value Theorem says that if f is continuous on a closed interval $[a,b]$, then f has an absolute minimum value and an absolute maximum value. According to the Closed Interval Method, we found these by evaluating f not only at the critical numbers but also at the endpoints a and b .

There is a similar situation for functions of two variables. Just as a closed interval contains its endpoints, a **closed set** in \mathbf{R}^2 is one that contains all its boundary points. [A boundary point of D is a point (a,b) such that every disk with center (a,b) contains points in D and also points not in D .]

A **bounded set** in \mathbf{R}^2 is one that is contained within some disk. In other words, it is finite in extent. Then, in terms of closed and bounded sets, we can state the following counterpart of the Extreme Value Theorem in two dimensions.

Extreme Value Theorem for Functions of Two Variables

If f is continuous on a closed, bounded set D in \mathbf{R}^2 , then f attains an absolute maximum value $f(x_1,y_1)$ and an absolute minimum value $f(x_2,y_2)$ at some points (x_1,y_1) and (x_2,y_2) in D .

We have the following extension of the Closed Interval Method.

To find the absolute maximum and minimum values of a continuous function f on a closed, bounded set D :

1. Find the values of f at the critical points of f in D .
2. Find the extreme values of f on the boundary of D .
3. The largest of the values from steps 1 and 2 is the absolute maximum value; the smallest of these values is the absolute minimum value.

Example 4. Find the absolute maximum and minimum values of the function $f(x,y) = x^2 - 2xy + 2y$ on the rectangle $D = \{(x,y) \mid 0 \leq x \leq 3, 0 \leq y \leq 2\}$.

Solution. Since f is a polynomial, it is continuous on the closed, bounded rectangle D , so last theorem tells us there is both an absolute maximum and an absolute minimum. According to step 1, we first find the critical points. These occur when

$$\begin{cases} f'_x = 2x - 2y, \\ f'_y = -2x + 2, \end{cases}$$

so the only critical point is $(1,1)$, and the value of there is $f(1,1) = 1$.

In step 2 we look at the values of f on the boundary of D , which consists of the four line segments L_1, L_2, L_3, L_4 , shown in Figure 12. On L_1 we have $y = 0$ and

$$f(x,0) = x^2 \quad 0 \leq x \leq 3$$

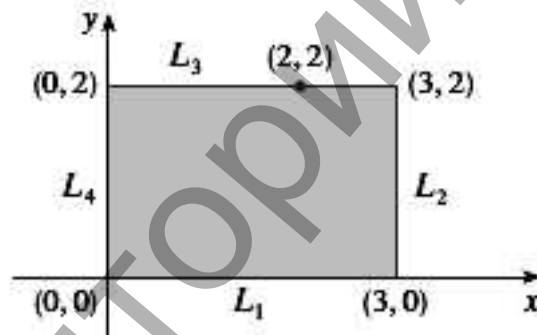

Figure 12

This is an increasing function of x , so its minimum value is $f(0,0) = 0$ and its maximum value is $f(3,0) = 9$. On L_2 we have $x = 3$ and $f(3,y) = 9 - 4y$, $0 \leq y \leq 2$.

This is a decreasing function of y , so its maximum value is $f(3,0) = 9$ and its minimum value is $f(3,2) = 1$. On L_3 we have $y = 2$ and $f(x,2) = x^2 - 4x + 4$, $0 \leq x \leq 3$.

By observing that $f(x,2) = (x-2)^2$, we see that the minimum value of this function is $f(2,2) = 0$ and the maximum value is $f(0,2) = 4$. Finally, on L_4 we have $x = 0$ and $f(0,y) = 2y$, $0 \leq y \leq 2$ with maximum value $f(0,2) = 4$ and minimum value $f(0,0) = 0$. Thus, on the boundary, the minimum value of f is 0 and the maximum is 9.

In step 3 we compare these values with the value $f(1,1) = 1$ at the critical point and conclude that the absolute maximum value of f on D is $f(3,0) = 9$ and the absolute minimum value is $f(0,0) = f(2,2) = 0$. Figure 13 shows the graph of f .

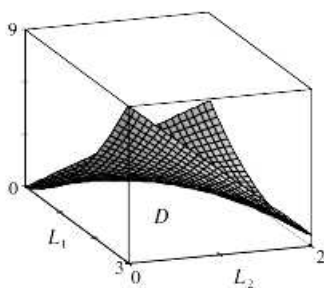

Figure 13

Exercise Set 4

Find the differential d^2z of

1. $z(x,y) = 3x^3y^2 + 2x^2y - 4xy^3 + 5x - 15y^2 + 3.$
2. $z(x,y) = 4y^3x^2 - 5y^2x + 3yx^3 + 3y - 5x^2 + 7.$
3. $z(x,y) = 2x^3y^2 - 2x^3y - 4xy^3 + 5x - 2y^3 + 7.$
4. $z(x,y) = 7y^3x^2 + 3y^2x - yx^3 + 3y^2 - 5x^2 + 1.$
5. $z(x,y) = 5x^3y^2 - 3x^2y + 2xy^3 - 4x + 8y^2 - 4.$
6. $z(x,y) = 2y^3x^2 - 4y^2x + 3yx^3 - 5y + 7x^2 - 6.$
7. $z(x,y) = 3x^2y^3 - 5x^2y + 2xy^3 + y - 4x + 7y^2 - 11.$
8. $z(x,y) = 3y^3x^2 + 5y^2x + 2yx^3 - 7y^2 + 2x - 12.$
9. $z(x,y) = 7x^3y^2 - 4x^2y - 7xy^3 + 2y^2 - 2x - 5.$
10. $z(x,y) = 2x^3y^2 - 3xy + 2xy^3 - 4x^2 + 4y - 5.$

Find the local maximum and minimum values and saddle points of

11. $z(x,y) = 2x^3 + 12xy + 3y^2 - 6x - 12y + 13.$
12. $z(x,y) = -3x^2 - 12xy - 2y^3 + 12x + 6y - 10.$
13. $z(x,y) = 2x^3 - 6xy - 3y^2 - 6x + 6y + 1.$
14. $z(x,y) = 2x^3 - 6xy + 3y^2 - 12y + 5.$
15. $z(x,y) = 2x^3 + 6xy - 3y^2 - 12x + 1.$
16. $z(x,y) = 2x^3 - 12xy + 3y^2 + 30x - 6y + 6.$
17. $z(x,y) = -3x^2 + 12xy - 2y^3 + 6x - 30y + 1.$
18. $z(x,y) = 2y^3 - 6xy - 3x^2 - 6y + 6x + 10.$
19. $z(x,y) = -3x^2 + 6xy - 2y^3 + 12x + 2.$
20. $z(x,y) = 2x^3 + 6xy - 3y^2 - 36x + 2.$

Find the absolute maximum and minimum values of f on the set D .

21. $z = 4(x-y) - x^2 - y^2, \quad \bar{D}: x+2y=4, x-2y=4, x=0.$
22. $z = x^2 - y^2 + 2xy - 4x, \quad \bar{D}: x-y+1=0, x=3, y=0.$
23. $z = x^2 + 2xy - 4x + 8y, \quad \bar{D}: x=0, y=0, x=1, y=2.$
24. $z = x^2 + 2xy - y^2 - 4x + 2, \quad \bar{D}: y=x+1, x=3, y=0.$

II INTEGRALS

2.1 Antiderivative

A physicist who knows the velocity of a particle might wish to know its position at a given time. An engineer who can measure the variable rate at which water is leaking from a tank wants to know the amount leaked over a certain time period. A biologist who knows the rate at which a bacteria population is increasing might want to deduce what the size of the population will be at some future time. In each case, the problem is to find a function F whose derivative is a known function f . If such a function F exists, it is called an *antiderivative* of f .

Definition. A function is called an **antiderivative** of f on an interval I if $F'(x) = f(x)$ for all x in I .

For instance, let $f(x) = x^2$. It isn't difficult to discover an antiderivative of f if we keep the Power Rule in mind. In fact, if $F(x) = \frac{1}{3}x^3$, then $F'(x) = x^2 = f(x)$. But the function $G(x) = \frac{1}{3}x^3 + 100$ also satisfies $G'(x) = x^2$. Therefore both F and G are antiderivatives of $f(x)$. Indeed, any function of the form $H(x) = \frac{1}{3}x^3 + C$, where C is a constant, is an antiderivative of $f(x)$. The question arises: Are there any others?

If two functions have identical derivatives on an interval, then they must differ by a constant. Thus if F and G are any two antiderivatives of f , then $F'(x) = f(x) = G'(x)$ so $F(x) - G(x) = C$, where C is a constant.

Theorem. If F is an antiderivative of f on an interval I , then the most general antiderivative of f on I is $F(x) + C$, where C is an arbitrary constant.

Going back to the function $f(x) = x^2$, we see that the general antiderivative of f is $F(x) = \frac{1}{3}x^3 + C$. By assigning specific values to the constant C , we obtain a family of functions whose graphs are vertical translates of one another (see Figure 1). This makes sense because each curve must have the same slope at any given value of x .

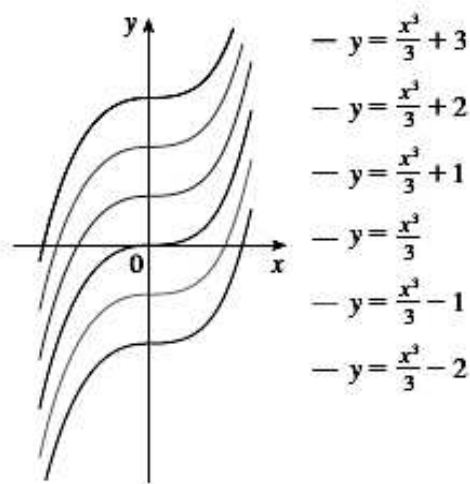

FIGURE 1

Example 1. Find the most general antiderivative of each of the following functions:

(a) $f(x) = \sin x$; (b) $f(x) = \frac{1}{x}$; (c) $f(x) = x^n \quad n \neq -1$.

Solution.

(a) If $F(x) = -\cos x$, then $F'(x) = \sin x$, so an antiderivative of $\sin x$ is $-\cos x$. By Theorem, the most general antiderivative is $G(x) = -\cos x + C$.

(b) Recall that $\frac{d}{dx}(\ln x) = \frac{1}{x}$. So on the interval $(0; +\infty)$ the general antiderivative of $\frac{1}{x}$ is $\ln x + C$. We also learned that $\frac{d}{dx}(\ln|x|) = \frac{1}{x}$ for all $x \neq 0$. Theorem then tells us that the general antiderivative of $f(x) = \frac{1}{x}$ is $\ln|x| + C$ on any interval that doesn't contain 0. In particular, this is true on each of the intervals $(-\infty; 0)$ and $(0; +\infty)$. So the general antiderivative of f is $F(x) = \ln|x| + C$.

(c) We use the Power Rule to discover an antiderivative of x^n . In fact, if $n \neq -1$, then $\frac{d}{dx}(x^n) = -\frac{d}{dx}\left(\frac{x^{n+1}}{n+1}\right) = \frac{(n+1)x^n}{n+1} = x^n$. Thus the general antiderivative of $f(x) = x^n$ is $F(x) = \frac{x^{n+1}}{n+1} + C$.

As in Example 1, every differentiation formula, when read from right to left, gives rise to an antidifferentiation formula. In Table 1 we list some particular antiderivatives. Each formula in the table is true because the derivative of the function in the right column appears in the left column. In particular, the first formula says that the antiderivative of a constant times a function is the constant times the antiderivative of the function. The second formula says that the antiderivative of a sum is the sum of the antiderivatives. (We use the notation $F'(x) = f(x)$ and $G'(x) = g(x)$).

Table 1

Function	Particular antiderivative	Function	Particular antiderivative
$cf(x)$	$cF(x)$	$\sin x$	$-\cos x$
$f(x) + g(x)$	$F(x) + G(x)$	$\frac{1}{\cos^2 x}$	$\operatorname{tg} x$
$x^n (n \neq -1)$	$\frac{x^{n+1}}{n+1}$	$-\frac{1}{\sin^2 x}$	$\operatorname{ctg} x$
$\frac{1}{x}$	$\ln x $	$\frac{1}{\sqrt{1-x^2}}$	$\arcsin x$
e^x	e^x	$\frac{1}{1+x^2}$	$\operatorname{arctg} x$
$\cos x$	$\sin x$	$\frac{1}{x^2 - a^2}$	$\frac{1}{2a} \ln \left \frac{x-a}{x+a} \right $

Example 2. Find all functions such that $g'(x) = 4 \sin x + \frac{2x^5 - \sqrt{x}}{x}$.

Solution. We first rewrite the given function as follows:

$$g'(x) = 4 \sin x + \frac{2x^5 - \sqrt{x}}{x} = 4 \sin x + 2x^4 - \frac{1}{\sqrt{x}}.$$

Thus we want to find an antiderivative of $g'(x) = 4 \sin x + 2x^4 - \frac{1}{\sqrt{x}} = 4 \sin x + 2x^4 - x^{-\frac{1}{2}}$.

Using the formulas in Table 1 together with Theorem, we obtain

$$g(x) = -4 \cos x + 2 \frac{x^5}{4+1} - \frac{x^{-\frac{1}{2}+1}}{-\frac{1}{2}+1} = -4 \cos x + \frac{2}{5}x^5 - 2\sqrt{x} + C.$$

In applications of calculus it is very common to have a situation as in Example 2, where it is required to find a function, given knowledge about its derivatives. An equation that involves the derivatives of a function is called a **differential equation**. These will be studied in some detail later, but for the present we can solve some elementary differential equations. The general solution of a differential equation involves an arbitrary constant (or constants) as in Example 2. However, there may be some extra conditions given that will determine the constants and therefore uniquely specify the solution.

Example 3. Find if $f'(x) = e^x + \frac{20}{1+x^2}$ and $f(0) = -2$.

Solution. The general antiderivative of $f'(x) = e^x + \frac{20}{1+x^2}$ is $f(x) = e^x + 20 \arctg x + C$.

To determine C we use the fact that $f(0) = -2$: $f(0) = e^0 + 20 \arctg 0 + C = -2$.

Thus we have $1 + 0 + C = -2$, $C = -3$, so the particular solution is $f(x) = e^x + 20 \arctg x - 3$.

2.2 Indefinite Integrals

Both parts of the Fundamental Theorem establish connections between antiderivatives and definite integrals. We need a convenient notation for antiderivatives that makes them easy to work with. Because of the relation given by the Fundamental Theorem between antiderivatives and integrals, the notation $\int f(x)dx$ is traditionally used for an antiderivative of f and is called an **indefinite integral**. Thus $\int f(x)dx = F(x) + C$ means $F'(x) = f(x)$.

For example, we can write $\int x^2 dx = \frac{1}{3}x^3 + C$ because $\frac{d}{dx}(\frac{1}{3}x^3 + C) = x^2$.

So we can regard an indefinite integral as representing an entire *family* of functions (one antiderivative for each value of the constant C).

We therefore restate the Table of Antidifferentiation Formulas from Section 2.1, together with a few others, in the notation of indefinite integrals. Any formula can be verified by differentiating the function on the right side and obtaining the integrand. For instance

$$\int \frac{dx}{\cos^2 x} = \operatorname{tg}x + C \text{ because } \frac{d}{dx}(\operatorname{tg}x) = \frac{1}{\cos^2 x}.$$

Table of Indefinite Integrals

$\int cf(x)dx = c \int f(x)dx.$	$\int (f(x) + g(x))dx = F(x) + G(x) + C.$
$\int f(ax + b)dx = \frac{1}{a}F(ax + b) + C.$	$\int dx = x + C.$
$\int x^n dx = \frac{x^{n+1}}{n+1} + C, n \neq -1.$	$\int \frac{dx}{\sqrt{x}} = 2\sqrt{x} + C.$
$\int a^x dx = \frac{a^x}{\ln a} + C.$	$\int e^x dx = e^x + C.$
$\int \cos x dx = \sin x + C.$	$\int \sin x dx = -\cos x + C.$
$\int \frac{dx}{\cos^2 x} = \operatorname{tg}x + C.$	$\int \frac{dx}{\sin^2 x} = -\operatorname{ctg}x + C.$
$\int \frac{dx}{x} = \ln x + C.$	$\int \frac{dx}{x^2 - a^2} = \frac{1}{2a} \ln \left \frac{x-a}{x+a} \right + C.$
$\int \frac{dx}{x^2 + a^2} = \frac{1}{a} \operatorname{arctg} \frac{x}{a} + C.$	$\int \frac{dx}{\sqrt{a^2 - x^2}} = \operatorname{arcsin} \frac{x}{a} + C.$
$\int \frac{dx}{\sqrt{x^2 - a^2}} = \ln x + \sqrt{x^2 - a^2} + C.$	$\int \frac{dx}{\sqrt{x^2 + a^2}} = \ln x + \sqrt{x^2 + a^2} + C.$

2.3 Techniques of Integration

In this chapter we develop techniques for using these basic integration formulas to obtain indefinite integrals of more complicated functions. We learned the most important method of integration, the Substitution Rule. The other general technique, integration by parts, is presented in next section. Then we learn methods that are special to particular classes of functions, such as trigonometric functions and rational functions. Integration is not as straightforward as differentiation; there are no rules that absolutely guarantee obtaining an indefinite integral of a function.

2.3.1 Integration by the introduction of derivative under the sign of differential

The simplest methods of integration include the presence of indefinite integrals with the aid of the fundamental rules of integration and table of integrals, integration by the introduction of derivative under the sign of differential.

All integral formulas remain valid, if we in them instead of variable x substitute a certain differentiated function from x . In this case for reducing of the integral to tabular integral in question sometimes it suffices to represent dx on one of the formulas:

1. $dx = d(x + a);$
2. $dx = \frac{1}{a}d(ax);$
3. $dx = \frac{1}{a}d(ax + b).$

Example 1. Find $\int \left(4x^3 - 2\sqrt[3]{x^2} + \frac{2}{x^3} + 1 \right) dx$.

Solution. $\int \left(4x^3 - 2\sqrt[3]{x^2} + \frac{2}{x^3} + 1 \right) dx =$ (we will use table of indefinite integrals)=
 $= 4 \cdot \int x^3 dx - 2 \cdot \int x^{\frac{2}{3}} dx + 2 \cdot \int x^{-3} dx + \int dx =$
 $= 4 \cdot \frac{x^4}{4} - 2 \cdot \frac{3}{5} x^{\frac{5}{3}} + 2 \cdot \frac{x^{-2}}{-2} + x + C = x^4 - \frac{6}{5} x^{\frac{5}{3}} - \frac{1}{x^2} + x + C.$

Example 2. Find $\int \frac{dx}{\sqrt{16x^2 + 9}}$.

Solution. $\int \frac{dx}{\sqrt{16x^2 + 9}} = \int \frac{dx}{\sqrt{(4x)^2 + 3^2}} = \frac{1}{4} \int \frac{d(4x)}{\sqrt{(4x)^2 + 3^2}} = \frac{1}{4} \ln |4x + \sqrt{16x^2 + 9}| + C.$

Example 3. Find $\int \frac{dx}{(2x-1)^5}$.

Solution.

$$\int \frac{dx}{(2x-1)^5} = \int (2x-1)^{-5} dx = \frac{1}{2} \int (2x-1)^{-5} d(2x-1) = \frac{1}{-8} (2x-1)^{-4} + C = -\frac{1}{8(2x-1)^4} + C.$$

Example 4. Find $\int \frac{dx}{\sin^2 6x}$.

Solution. $\int \frac{dx}{\sin^2 6x} = \frac{1}{6} \int \frac{d(6x)}{\sin^2 6x} = -\frac{1}{6} \operatorname{ctg} 6x + C.$

Example 5. Find $\int \frac{dx}{x^2 + 2x + 3}$.

Solution. $\int \frac{dx}{x^2 + 2x + 3} = \int \frac{d(x+1)}{(x+1)^2 + 2} = \frac{1}{\sqrt{2}} \operatorname{arctg} \frac{x+1}{\sqrt{2}} + C.$

In the next examples the method of the introduction of derivative under the sign of differential will be used. It is based on the use of the formula $f'(x)dx = d(f(x))$, from which, in particular, it follows that

$$x dx = \frac{1}{2} (x^2)' dx = \frac{1}{2} d(x^2);$$

$$x^2 dx = \frac{1}{3} (x^3)' dx = \frac{1}{3} d(x^3);$$

$$\frac{dx}{x} = (\ln x)' dx = d(\ln x);$$

$$\cos x dx = (\sin x)' dx = d(\sin x);$$

$$\sin x dx = -(\cos x)' dx = -d(\cos x);$$

$$e^x dx = (e^x)' dx = d(e^x);$$

$$\frac{dx}{\cos^2 x} = (\operatorname{tg} x)' dx = d(\operatorname{tg} x);$$

$$\frac{dx}{\sin^2 x} = -(\operatorname{ctg} x)' dx = -d(\operatorname{ctg} x);$$

$$\frac{dx}{1+x^2} = (\operatorname{arctg} x)' dx = d(\operatorname{arctg} x).$$

Example 6. Find $\int x^2 \sqrt{4+x^3} dx$.

$$\begin{aligned} \text{Solution. } \int x^2 \sqrt{4+x^3} dx &= \frac{1}{3} \int (4+x^3)^{\frac{1}{2}} (4+x^3)' dx = \frac{1}{3} \int (4+x^3)^{\frac{1}{2}} d(4+x^3) = \\ &= \frac{2}{9} (4+x^3)^{\frac{3}{2}} + C = \frac{2}{9} \sqrt{(4+x^3)^3} + C. \end{aligned}$$

Example 7. Find $\int \frac{dx}{(x+1)\ln(x+1)}$.

$$\text{Solution. } \int \frac{dx}{(x+1)\ln(x+1)} = \int \frac{(\ln(x+1))' dx}{\ln(x+1)} = \int \frac{d(\ln(x+1))}{\ln(x+1)} = \ln |\ln(x+1)| + C.$$

Example 8. Find $\int \frac{dx}{\arcsin x \sqrt{1-x^2}}$.

$$\text{Solution. } \int \frac{dx}{\arcsin x \sqrt{1-x^2}} = \int \frac{(\arcsin x)' dx}{\arcsin x} = \int \frac{d(\arcsin x)}{\arcsin x} = \ln |\arcsin x| + C.$$

Example 9. Find $\int \frac{x - \arctg x}{1+x^2} dx$.

$$\begin{aligned} \text{Solution. } \int \frac{x - \arctg x}{1+x^2} dx &= \int \frac{x dx}{1+x^2} - \int \frac{\arctg x}{1+x^2} dx = \frac{1}{2} \int \frac{d(x^2+1)}{x^2+1} - \int \arctg x d(\arctg x) = \\ &= \frac{1}{2} \ln(x^2+1) - \frac{1}{2} \arctg^2 x + C. \end{aligned}$$

Exercise Set 5

Evaluate the integral

1. $\int \left(2\sqrt{x^5} - \frac{8}{x^3} + \frac{4x}{\sqrt{x^3}} \right) dx.$
2. $\int \left(\frac{3}{\sqrt{5x^2+4}} - \frac{1}{3x^2-4} \right) dx.$
3. $\int \left(\frac{6}{(2+4x)^{13}} - 5(3x+1)^{15} \right) dx.$
4. $\int (2\sin(1-6x) + 4e^{3+5x}) dx.$
5. $\int \sqrt{\sin x} \cos x dx.$
6. $\int \sqrt{1+\ln x} \frac{dx}{x}.$
7. $\int \frac{dx}{\sin^2(1-3x)}.$
8. $\int \frac{dx}{2x^2+6x+4}.$
9. $\int \frac{x^3 dx}{\sqrt{5+x^4}}.$
10. $\int \frac{\text{tg}^4 x}{\cos^2 x} dx.$
11. $\int \frac{2x - 5 \arccos x}{\sqrt{1-x^2}} dx.$
12. $\int \frac{e^{3x}}{e^{6x} + 25} dx.$
13. $\int \sin x \cos^{-2} x dx.$
14. $\int \sin x \cos^2 x dx.$

$$15. \int \frac{dx}{\sqrt{x^2 + 4x + 20}}.$$

$$17. \int \frac{dx}{(x+3)\ln^4(x+3)}.$$

$$19. \int \frac{\operatorname{tg}^2 x + 1}{\cos^2 x} dx.$$

$$21. \int \frac{e^{3x}}{e^{3x} + 5} dx.$$

$$23. \int (2\sin(1-8x) + 6e^{3+4x}) dx.$$

$$25. \int \frac{dx}{\sin^2(3x+2)}.$$

$$27. \int \frac{1 + \operatorname{tg} x}{\cos^2 x} dx.$$

$$29. \int \frac{2x - 5\operatorname{arctg}^2 x}{1+x^2} dx.$$

$$16. \int \frac{dx}{\cos^2(3x+2)}.$$

$$18. \int \frac{x^2 dx}{\sqrt{7+x^3}}.$$

$$20. \int \frac{x - 2\operatorname{arctg} x}{1+x^2} dx.$$

$$22. \int (2\cos(8-4x) + 6e^{3-7x}) dx.$$

$$24. \int \frac{\ln^4(x-2) dx}{(x-2)}.$$

$$26. \int \frac{x^3 dx}{\sqrt{1+5x^4}}.$$

$$28. \int \frac{dx}{x^2 - 8x - 9}.$$

$$30. \int \frac{e^{2x}}{e^{4x} + 5} dx.$$

2.3.2 Integration by Parts

Every differentiation rule has a corresponding integration rule. For instance, the Substitution Rule for integration corresponds to the Chain Rule for differentiation. The rule that corresponds to the Product Rule for differentiation is called the rule for *integration by parts*.

The method of integration by parts based on the use of the formula

$$\int u(x)dv(x) = u(x)v(x) - \int v(x)du(x) \text{ or } \int u dv = uv - \int v du,$$

where $u = u(x), v = v(x)$ are the continuously differentiated functions.

The application of a formula is expedient, when under the integral sign there is a work of functions of different classes. In certain cases it is necessary to use the formula of integration in parts several times.

Example 1. Find $\int \ln x dx$.

Solution.

$$\int \ln x dx = \left. \begin{array}{l} u = \ln x, \quad du = \frac{dx}{x} \\ dv = dx, \quad v = x \end{array} \right| = x \ln x - \int x \frac{dx}{x} = x \ln x - \int dx = x \ln x - x + C = x(\ln x - 1) + C.$$

Example 2. Find $\int (2x+1)\cos 3x dx$.

Solution.

$$\int (2x+1)\cos 3x dx = \left| \begin{array}{l} u = 2x+1, \quad du = 2dx \\ dv = \cos 3x dx, \quad v = \frac{1}{3}\sin 3x \end{array} \right| = \frac{2x+1}{3}\sin 3x - \frac{2}{3}\int \sin 3x dx =$$

$$= \frac{2x+1}{3}\sin 3x + \frac{2}{9}\cos 3x + C.$$

Example 3. Find $\int 2x \arctg x dx$.

Solution.

$$\int 2x \arctg x dx = \left| \begin{array}{l} u = \arctg x, \quad du = \frac{dx}{1+x^2} \\ dv = 2x dx, \quad v = x^2 \end{array} \right| = x^2 \arctg x - \int \frac{x^2 dx}{1+x^2} = x^2 \arctg x - \int \frac{(x^2+1)-1}{1+x^2} dx =$$

$$= x^2 \arctg x - \int dx + \int \frac{dx}{1+x^2} = x^2 \arctg x - x + \arctg x + C.$$

Example 4. Find $\int x^2 \sin x dx$.

Solution.

$$\int x^2 \sin x dx = \left| \begin{array}{l} u = x^2, \quad du = 2x dx \\ dv = \sin x dx, \quad v = -\cos x \end{array} \right| = -x^2 \cos x + 2 \int x \cos x dx =$$

$$= \left| \begin{array}{l} u = x, \quad du = dx \\ dv = \cos x dx, \quad v = \sin x \end{array} \right| = -x^2 \cos x + 2 \left(x \sin x - \int \sin x dx \right) = -x^2 \cos x + 2x \sin x + 2 \cos x + C$$

Exercise Set 6

Evaluate the integral

1. $\int (1-3x)\ln(4x) dx$.
2. $\int (2x+3)\cos 5x dx$.
3. $\int (1-x^2 \sin x) dx$.
4. $\int x \arctg 2x dx$.
5. $\int (5x^2+1)e^{-2x} dx$.
6. $\int \frac{\ln^2 x}{x^2} dx$.
7. $\int x^3 e^{-x^2} dx$.
8. $\int \sin(\ln x) dx$.
9. $\int \frac{x \cos x}{\sin^2 x} dx$.
10. $\int x \ln(2x) dx$.
11. $\int (3-x)\sin 4x dx$.
12. $\int (x^2-4)\cos x dx$.
13. $\int x \ln(5x) dx$.
14. $\int (1-x)\cos 2x dx$.
15. $\int (3-x^2)\sin x dx$.

2.3.3 Replacement of Variable in the Indefinite Integral

The method of integration by replacement of a variablis based on the use of the formula

$$\int f(x) dx = \int g(f(x))f'(x) dx = \int g(t) dt.$$

Example 1. Find $\int x\sqrt{x-1} dx$.

Solution.

$$\int x\sqrt{x-1} dx = 2 \int (t^2 + 1)t^2 dt = 2 \int (t^4 + t^2) dt = 2 \int t^4 dt + 2 \int t^2 dt = \frac{2}{5}t^5 + \frac{2}{3}t^3 + C =$$

$$= \frac{2}{15}t^3(3t^2 + 5) + C = \frac{2}{15}\sqrt{(x-1)^3}(3x+2) + C, \text{ where } x-1 = t^2; dx = d(t^2 + 1) = 2tdt.$$

Example 2. Find $\int (1 + \sin x)^{\frac{1}{3}} \cos x dx$.

Solution. $\int (1 + \sin x)^{\frac{1}{3}} \cos x dx = \int t^{\frac{1}{3}} dt = \frac{3}{4}t^{\frac{4}{3}} + C = \frac{3}{4}(1 + \sin x)^{\frac{4}{3}} + C$, where $t = 1 + \sin x$.

Example 3. Find $\int \frac{\sqrt[4]{x+1} + 2}{\sqrt{x+1}} dx$.

Solution. $\int \frac{\sqrt[4]{x+1} + 2}{\sqrt{x+1}} dx = \left| \begin{array}{l} x+1 = t^4, \quad dx = 4t^3 dt \\ x = t^4 - 1. \end{array} \right| =$

$$= \int \frac{t+2}{t^2} 4t^3 dt = 4 \int (t^2 + 2t) dt = \frac{4}{3}t^3 + 4t^2 + C = \frac{4}{3}(x+1)^{\frac{3}{4}} + 4\sqrt{x+1} + C.$$

Exercise Set 7

Evaluate the integral

1. $\int \frac{dx}{1 + \sqrt{x+3}}$

2. $\int e^{\sqrt{4-3x}} \frac{dx}{\sqrt{4-3x}}$

3. $\int \frac{\sqrt[3]{x} + 2}{\sqrt{x}} dx$

4. $\int x\sqrt{1-2x} dx$

5. $\int e^{\sqrt{5+x}} \frac{dx}{\sqrt{5+x}}$

6. $\int \frac{\sqrt[3]{x+1} + 3}{\sqrt{x+1}} dx$

7. $\int \frac{dx}{2 + \sqrt{3-x}}$

8. $\int e^{\sqrt{4-3x}} \frac{dx}{\sqrt{4-3x}}$

9. $\int \frac{1}{\sqrt{x} + \sqrt[4]{x}} dx$

2.3.4 Integration of Rational Functions

The relation of two polynomials is called the rational function (rational fraction), i.e., the fraction of the form $\frac{P_n(x)}{Q_m(x)}$, where $P_n(x)$ -the polynomial of the degree n , $Q_m(x)$ -the polynomial of the degree m . If $n \geq m$, that rational fraction is called incorrect, if $n < m$ that rational fraction is called correct.

Theorem. Any incorrect rational fraction can be uniquely represented in the form the sum of polynomial and correct rational fraction

$$\frac{P(x)}{Q(x)} = M(x) + \frac{R(x)}{Q(x)}$$

Example 1. Rational fraction of the form $\frac{x^5 - 3x^4 + 5x^3 - 1}{x^3 - 2x}$ is incorrect.

Solution. Since the degree of numerator ($n=5$) is more than the degree of denominator ($m=3$). We divide the polynomial of numerator "by corner" into the polynomial of denominator. Then in the quotient we obtain polynomial $M(x)$, and in the remainder polynomial $R(x)$.

$$\frac{x^5 - 3x^4 + 5x^3 - 1}{x^3 - 2x} = x^2 - 3x + 7 - \frac{6x^2 - 14x + 1}{x^3 - 2x}.$$

The rational fractions of the following forms are called the simplest rational functions:

1. $\frac{A}{x-a}$;
2. $\frac{Ax+B}{x^2+px+q}$, where $D = p^2 - 4q < 0$;
3. $\frac{A}{(x-a)^m}$, $m > 1, m \in \mathbb{N}$;
4. $\frac{Ax+B}{(x^2+px+q)^m}$, $D < 0, m > 1, m \in \mathbb{N}$.

Integration of such functions:

$$\int \frac{A}{x-a} dx = A \ln |x-a| + C,$$

$$\int \frac{A}{(x-a)^m} dx = A \int (x-a)^{-m} d(x-a) = \frac{A}{-m+1} (x-a)^{-m+1} + C,$$

$$\int \frac{Ax+B}{ax^2+bx+c} dx.$$

It is necessary to isolate the perfect square in the denominator of integrand in square trinomial

$$ax^2 + bx + c = a \left(x^2 + 2x \frac{b}{2a} + \frac{b^2}{4a^2} \right) + c - \frac{b^2}{4a} = a \left(x + \frac{b}{2a} \right)^2 + c - \frac{b^2}{4a}.$$

Then to make the variable $x + \frac{b}{2a} = t$, $x = t - \frac{b}{2a}$, $dx = dt$.

Example 2. Find $\int \frac{xdx}{2x^2 + 2x + 5}$

Solution.

$$\int \frac{xdx}{2x^2 + 2x + 5} = \frac{1}{2} \int \frac{xdx}{\left(x + \frac{1}{2}\right)^2 + \frac{9}{4}} = \left. \begin{array}{l} x + \frac{1}{2} = t, \\ dx = dt \end{array} \right| x = t - \frac{1}{2} = \frac{1}{2} \int \frac{t - \frac{1}{2}}{t^2 + \frac{9}{4}} dt = I.$$

Theorem. It is possible to uniquely represent each correct rational function $\frac{P(x)}{Q(x)}$ in the form of the sums of the simplest rational functions.

We factor the denominator as

$$Q(x) = (x-a)^k (x-b)(x^2+px+q)(x^2+px+q)^m.$$

Then rational function can be represented in the form

$$\frac{P(x)}{Q(x)} = \frac{A_1}{(x-a)^k} + \frac{A_2}{(x-a)^{k-1}} + \dots + \frac{A_k}{x-a} + \frac{B}{x-b} + \frac{Cx+D}{x^2+px+q} + \frac{E_1x+F_1}{(x^2+px+q)^m} + \frac{E_2x+F_2}{(x^2+px+q)^{m-1}} + \dots + \frac{E_mx+F_m}{x^2+px+q},$$

where $A_1, A_2, \dots, A_k, B, C, D, E_1, F_1, \dots, E_m, F_m$ – are real numbers, which must be determined.

In the obtained decomposition we reduce both parts to the common denominator. We make level numerators. Obtained equation is correct for any x . We find unknown coefficients either

by the method of particular values or equalizing coefficients with the identical degrees x , or combining these two methods.

Example 3. Find

$$\text{a) } I_1 = \int \frac{2x^2 - x + 3}{x^3 + x^2 - 2x} dx. \quad \text{b) } I_2 = \int \frac{x^2 + 4}{x^3(x+1)^2} dx. \quad \text{c) } I_3 = \int \frac{2x^2 - 3x + 1}{x^3 + 1} dx$$

Solution.

a) We factor the denominator as

$$Q(x) = x^3 + x^2 - 2x = x(x^2 + x - 2) = x(x-1)(x+2).$$

The partial fraction decomposition of the integrand has the form:

$$\frac{2x^2 - x + 3}{x^3 + x^2 - 2x} = \frac{2x^2 - x + 3}{x(x-1)(x+2)} = \frac{A}{x} + \frac{B}{x-1} + \frac{C}{x+2} = \frac{A(x-1)(x+2) + Bx(x+2) + Cx(x-1)}{x(x-1)(x+2)}.$$

We make level the numerators

$$2x^2 - x + 3 = A(x-1)(x+2) + Bx(x+2) + Cx(x-1).$$

The polynomials in last equation are identical, so their coefficients must be equal. Let's choose values of x that simplify the equation.

$$x = 0, \quad 3 = A(-1)2, \quad A = -\frac{3}{2},$$

$$x = 1, \quad 2 - 1 + 3 = 3B, \quad B = \frac{4}{3},$$

$$x = -2, \quad 8 + 2 + 3 = C(-2)(-3), \quad C = \frac{13}{6}.$$

The expansion of rational function into the partial fractions was obtained

$$I_1 = \int \frac{2x^2 - x + 3}{x^3 + x^2 - 2x} dx = \int \left(-\frac{3}{2x} + \frac{4}{3(x-1)} + \frac{13}{6(x+2)} \right) dx = -\frac{3}{2} \ln|x| + \frac{4}{3} \ln|x-1| + \frac{13}{6} \ln|x+2| + C.$$

b) The partial fraction decomposition of the integrand has the form:

$$\frac{x^2 + 4}{x^3(x+1)^2} = \frac{A}{x^3} + \frac{B}{x^2} + \frac{C}{x} + \frac{D}{(x+1)^2} + \frac{E}{x+1} = \frac{(A+Bx+Cx^2)(x+1)^2 + (D+Ex+E)x^3}{x^3(x+1)^2}.$$

We make level the numerators

$$x^2 + 4 = (A+Bx+Cx^2)(x^2 + 2x + 1) + (D+Ex+E)x^3,$$

$$x^2 + 4 = (C+E)x^4 + (B+2C+D+E)x^3 + (A+2B+C)x^2 + (B+2A)x + A.$$

The polynomials in last equation are identical, so their coefficients must be equal. The coefficients of polynomials are equal and the constant terms are equal. This gives the following system of equations for A , B , and C .

$$x^4 \quad C+E=0, \quad E=-C=-13.$$

$$x^3 \quad B+2C+D+E=0, \quad D=-B-2C-E=8-26+13=-5.$$

$$x^2 \quad A+2B+C=1, \quad C=1-A-2B=1-4+16=13.$$

$$x^1 \quad B+2A=0, \quad B=-2A=-8.$$

$$x^0 \quad A=4. \quad A=4.$$

The expansion of rational function into the partial fractions was obtained

$$\frac{x^2+4}{x^3(x+1)^2} = \frac{4}{x^3} - \frac{8}{x^2} + \frac{13}{x} - \frac{5}{(x+1)^2} - \frac{13}{x+1}.$$

$$I_2 = -\frac{2}{x^2} + \frac{8}{x} + 13\ln|x| + \frac{5}{x+1} - 13\ln|x+1| + C.$$

c) The partial fraction decomposition of the integrand has the form

$$\frac{2x^2-3x+1}{x^3+1} = \frac{2x^2-3x+1}{(x+1)(x^2-x+1)} = \frac{A}{x+1} + \frac{Bx+C}{x^2-x+1}.$$

The polynomials in last equation are identical, so their coefficients must be equal. The coefficients of polynomials are equal and the constant terms are equal. This gives the following system of equations for A, B, and C.

$$\begin{cases} A+B=2, \\ -A+B+C=-3, \\ A+C=1. \end{cases} \Leftrightarrow \begin{cases} B=2-A, \\ C=1-A, \\ -A+2-A+1-A=-3. \end{cases} \Leftrightarrow \begin{cases} B=2-A, \\ C=1-A, \\ -3A=-6. \end{cases} \Leftrightarrow \begin{cases} A=2, \\ B=0, \\ C=-1. \end{cases}$$

The expansion of rational function into the partial fractions was obtained

$$I_3 = \int \frac{2x^2-3x+1}{x^3+1} dx = \int \left(\frac{2dx}{x+1} - \frac{dx}{x^2-x+1} \right) = 2\ln|x+1| - \int \frac{d(x-\frac{1}{2})}{(x-\frac{1}{2})^2 + \frac{3}{4}} =$$

$$= 2\ln|x+1| - \frac{2}{\sqrt{3}} \operatorname{arctg} \frac{2x-1}{\sqrt{3}} + C.$$

Exercise Set 8

Evaluate the integral

1. $\int \frac{(x+2)dx}{2x^2+6x+4}$

2. $\int \frac{xdx}{x^2+6x+14}$

3. $\int \frac{xdx}{2x^2+4x+9}$

4. $\int \frac{x-4}{x^2-5x+6} dx$

5. $\int \frac{x^5+x^4-8}{x^3-4x} dx$

6. $\int \frac{x^3+1}{x^3-x^2} dx$

7. $\int \frac{2x^2-3x-3}{(x-1)(x^2-2x+5)} dx$

8. $\int \frac{x^2 dx}{x^4-1}$

9. $\int \frac{dx}{x^4+1}$

10. $\int \frac{2xdx}{(x+1)(x^2+1)^2}$

11. $\int \frac{4x^3-2x^2+6x-1}{(x^2-1)^2} dx$

12. $\int \frac{2x^2-7}{(x^3+16x)(x-3)} dx$

13. $\int \frac{6x^2-3x+7}{(x+2)(x^2+4)^2} dx$

14. $\int \frac{x^2+x-8}{x^3-4x} dx$

15. $\int \frac{2x-3}{(x^2-1)(x+2)} dx$

2.3.5 Trigonometric Integrals

In this section we use trigonometric identities to integrate certain combinations of trigonometric functions. We start with powers of sine and cosine.

a) If $\int \sin^{2m} x \cos^{2n} x dx$ ($m > 0, n > 0$), element of integration must be converted with the

aid of the formulas of reduction in the degree

$$\cos^2 x = \frac{1 + \cos 2x}{2}, \quad \sin^2 x = \frac{1 - \cos 2x}{2}.$$

b) If $\int \sin^m x \cos^n x dx$, $\int \sin^m x \sin^n x dx$, $\int \cos^m x \cos^n x dx$, the multiplication of trigonometric functions should be replaced with the sum

$$\sin^m x \cos^n x = \frac{1}{2} (\sin(m+n)x + \sin(m-n)x),$$

$$\sin^m x \sin^n x = \frac{1}{2} (\cos(m-n)x - \cos(m+n)x),$$

$$\cos^m x \cos^n x = \frac{1}{2} (\cos(m-n)x + \cos(m+n)x).$$

c) If $\int R(\sin x, \cos x) dx$ where R - the rational function of its arguments, with the aid of the universal trigonometric substitution $t = \operatorname{tg} \frac{x}{2}$ it is led to the integral of the rational function variable t .

$$\int R(\sin x, \cos x) dx = \left| \begin{array}{l} \operatorname{tg} \frac{x}{2} = t, \quad \sin x = \frac{2t}{1+t^2} \\ \cos x = \frac{1-t^2}{1+t^2}, \quad dx = \frac{2dt}{1+t^2} \end{array} \right| = \int R_1(t) dt.$$

d) If $R(-\sin x, \cos x) = -R(\sin x, \cos x)$, the substitution is used $t = \cos x$.

e) If $R(\sin x, -\cos x) = -R(\sin x, \cos x)$, the substitution is used $t = \sin x$.

f) If $R(-\sin x, -\cos x) = R(\sin x, \cos x)$, the substitution is used $t = \operatorname{tg} x$.

Example 1. Find $\int \frac{\operatorname{ctg}^6 3x}{\sin^2 3x} dx$.

Solution.

$$\int \frac{\operatorname{ctg}^6 3x}{\sin^2 3x} dx = \left| \begin{array}{l} t = \operatorname{ctg} 3x, \quad dt = -\frac{3dx}{\sin^2 3x} \\ \frac{dx}{\sin^2 3x} = -\frac{dt}{3} \end{array} \right| = -\frac{1}{3} \int t^6 dt = -\frac{1}{21} t^7 + C = -\frac{\operatorname{ctg}^7 3x}{21} + C.$$

Example 2. Find $\int \sin^3 2x \cos^4 2x dx$.

Solution.

$$\int \sin^3 2x \cos^4 2x dx = \int \sin^2 2x \cos^4 2x \sin 2x dx = \left| \begin{array}{l} t = \cos 2x, \quad dt = -2 \sin 2x dx \\ \sin^2 2x = 1 - \cos^2 2x = 1 - t^2, \quad \sin 2x dx = -\frac{1}{2} dt \end{array} \right| =$$

$$= -\frac{1}{2} \int (1-t^2)t^4 dt = \frac{1}{2} \int (t^6 - t^4) dt = \frac{t^7}{14} - \frac{t^5}{10} + C = \frac{\cos^7 2x}{14} - \frac{\cos^5 2x}{10} + C.$$

Example 3. Find $\int \sin^2 x \cos^2 x dx$.

Solution.

$$\begin{aligned} \int \sin^2 x \cos^2 x dx &= \frac{1}{4} \int (2 \sin x \cos x)^2 dx = \frac{1}{4} \int \sin^2 2x dx = \frac{1}{4} \int \frac{1 - \cos 4x}{2} dx = \\ &= \frac{1}{8} \int (dx - \cos 4x dx) = \frac{1}{8} \left(x - \frac{1}{4} \sin 4x \right) + C = \frac{1}{8} x - \frac{1}{32} \sin 4x + C. \end{aligned}$$

Example 4. Find $\int \operatorname{tg}^5 x dx$.

Solution.

$$\begin{aligned} \int \operatorname{tg}^5 x dx &= \left| \begin{array}{l} t = \operatorname{tg} x, \quad x = \operatorname{arctg} t \\ dx = \frac{dt}{1+t^2} \end{array} \right| = \int \frac{t^5 dt}{1+t^2} = \int \frac{t^4}{1+t^2} t dt = \frac{1}{2} \int \frac{t^4}{1+t^2} d(t^2) = \left| t^2 = z \right| = \\ &= \frac{1}{2} \int \frac{z^2}{1+z} dz = \frac{1}{2} \int \frac{(z^2 - 1) + 1}{z+1} dz = \frac{1}{2} \int \left(z - 1 + \frac{1}{z+1} \right) dz = \frac{1}{2} \left(\frac{z^2}{2} - z + \ln |z+1| \right) + C = \\ &= \frac{1}{4} (\operatorname{tg}^4 x - 2 \operatorname{tg}^2 x + 2 \ln(1 + \operatorname{tg}^2 x)) + C. \end{aligned}$$

Example 5. Find $\int \sin x \sin 3x \sin 2x dx$.

Solution.

$$\begin{aligned} \int \sin x \sin 3x \sin 2x dx &= \frac{1}{2} \int (\cos 2x - \cos 4x) \sin 2x dx = \\ &= \frac{1}{2} \int \cos 2x \sin 2x dx - \frac{1}{2} \int \cos 4x \sin 2x dx = \frac{1}{4} \int \sin 4x dx - \frac{1}{4} \int (\sin 6x - \sin 2x) dx = \\ &= -\frac{\cos 4x}{16} + \frac{\cos 6x}{24} - \frac{\cos 2x}{8} + C. \end{aligned}$$

Example 6. Find $\int \frac{dx}{2 \sin x + 3 \cos x + 5}$.

Solution.

$$\begin{aligned} \int \frac{dx}{2 \sin x + 3 \cos x + 5} &= \left| \begin{array}{l} \operatorname{tg} \frac{x}{2} = t, \quad dx = \frac{2dt}{1+t^2} \\ \cos x = \frac{1-t^2}{1+t^2}, \quad \sin x = \frac{2t}{1+t^2} \end{array} \right| = \int \frac{2dt}{(1+t^2) \left(\frac{4t}{1+t^2} + 3 \frac{1-t^2}{1+t^2} + 5 \right)} = \\ &= \int \frac{2dt}{4t + 3 - 3t^2 + 5 + 5t^2} = \int \frac{dt}{t^2 + 2t + 4} = \int \frac{dt}{(t+1)^2 + 3} = \frac{1}{\sqrt{3}} \operatorname{arctg} \frac{t+1}{\sqrt{3}} + C = \\ &= \frac{1}{\sqrt{3}} \operatorname{arctg} \frac{1 + \operatorname{tg} \frac{x}{2}}{\sqrt{3}} + C. \end{aligned}$$

Example 7. Find $\int \frac{dx}{1+\sin^2 x}$

Solution.

$$\int \frac{dx}{1+\sin^2 x} = \int \frac{dx}{2\sin^2 x + \cos^2 x} = \int \frac{dx}{\sin^2 x(2 + \operatorname{ctg}^2 x)} = -\int \frac{d(\operatorname{ctg} x)}{\operatorname{ctg}^2 x + 2} = -\frac{1}{\sqrt{2}} \operatorname{arctg} \frac{\operatorname{ctg} x}{\sqrt{2}} + C.$$

Exercise Set 9

Evaluate the integral

1. $\int \frac{\operatorname{tg}^7 3x}{\cos^2 3x} dx.$

2. $\int \sin^7 x \cos^5 x dx.$

3. $\int \sin^4 x \cos^4 x dx.$

4. $\int \frac{dx}{\cos^4 5x}.$

5. $\int \cos 3x \sin 6x dx.$

6. $\int \frac{dx}{\sin^2 x - 2\sin x \cos x - 3\cos^2 x}.$

7. $\int \frac{\sin 8x}{16 - \cos^2 8x} dx.$

8. $\int \sqrt[9]{\cos^7 x} \sin 2x dx.$

9. $\int \cos^4 2x dx.$

10. $\int \frac{dx}{\sin^4 x \cos^2 x}.$

11. $\int \sin 3x \cos 5x dx.$

12. $\int \frac{dx}{3\sin x + \cos x + 1}.$

13. $\int \frac{dx}{16\sin^2 x + \cos^2 x}.$

14. $\int \frac{\sin^3 x}{\cos^4 x} dx.$

15. $\int \frac{\cos^4 + \sin^4 x}{\cos^2 x - \sin^2 x} dx.$

2.3.6 Integration of Nonrational Functions

Let us examine such nonrational functions, whose integration is reduced with the aid of the specific replacement of the variable of integration to the integration of some rational functions.

a) If $\int \frac{Ax+B}{\sqrt{ax^2+bx+c}} dx.$

It is necessary to isolate the perfect square in the denominator of integrand in square trinomial

$$ax^2 + bx + c = a \left(x^2 + 2x \frac{b}{2a} + \frac{b^2}{4a^2} \right) + c - \frac{b^2}{4a} = a \left(x + \frac{b}{2a} \right)^2 + c - \frac{b^2}{4a}.$$

Then to make the variable $x + \frac{b}{2a} = t$, $x = t - \frac{b}{2a}$, $dx = dt$.

Example 1. Find $\int \frac{3x-1}{\sqrt{x^2-4x+8}} dx.$

Solution.

$$\int \frac{3x-1}{\sqrt{x^2-4x+8}} dx = \int \frac{3x-1}{\sqrt{(x-2)^2+4}} dx = \left. \begin{array}{l} x-2=t, \quad dx=dt \\ x=t+2. \end{array} \right| = \int \frac{3t+5}{\sqrt{t^2+4}} dt =$$

$$= 3 \int \frac{tdt}{\sqrt{t^2+4}} + 5 \int \frac{dt}{\sqrt{t^2+4}} = \frac{3}{2} \int \frac{d(t^2+4)}{\sqrt{t^2+4}} + 5 \int \frac{dt}{\sqrt{t^2+4}} = 3\sqrt{t^2+4} + 5 \ln |t + \sqrt{t^2+4}| + C =$$

$$= 3\sqrt{x^2-4x+8} + 5 \ln |x-2 + \sqrt{x^2-4x+8}| + C.$$

b) If $\int \frac{dx}{(x-a)^n \sqrt{ax^2+bx+c}}$, we must use next substitution $\frac{1}{x-a} = t$.

c) If $\int R(x, \sqrt[k]{x}, \sqrt[m]{x}, L, \sqrt[s]{x}) dx$, where R -the rational function of its arguments, we must use next substitution $x = t^n$, (n- all least common multiple indices k,m,L ,s,).

d) If $\int R(x, \sqrt[n]{ax+b}) dx$, we must use next substitution $ax+b = t^n$.

e) If $\int R(\sqrt{x^2-a^2}, x) dx$; $\int R(\sqrt{x^2+a^2}, x) dx$; $\int R(\sqrt{a^2-x^2}, x) dx$, where R-the rational function of its arguments, we must use trigonometric substitution.

In the following table we list trigonometric substitutions that are effective for the given radical expressions because of the specified trigonometric identities. In each case the restriction on θ is imposed to ensure that the function that defines the substitution is one-to-one.

Table of trigonometric substitutions

Expression	Substitution	Identity
$\sqrt{a^2-x^2}$	$x = a \sin \theta, -\frac{\pi}{2} \leq \theta \leq \frac{\pi}{2}$	$1 - \sin^2 \theta = \cos^2 \theta$
$\sqrt{a^2+x^2}$	$x = a \tan \theta, -\frac{\pi}{2} < \theta < \frac{\pi}{2}$	$1 + \tan^2 \theta = \frac{1}{\cos^2 \theta}$
$\sqrt{x^2-a^2}$	$x = \frac{a}{\cos^2 \theta}, 0 \leq \theta < \frac{\pi}{2}$	$1 + \tan^2 \theta = \frac{1}{\cos^2 \theta}$

Example 2. Find $\int \frac{\sqrt{x} dx}{x - \sqrt[3]{x^2}}$

Solution.

$$\begin{aligned} \int \frac{\sqrt{x} dx}{x - \sqrt[3]{x^2}} &= \left| \begin{array}{l} x = t^6, \quad dx = 6t^5 dt \\ \sqrt{x} = t^3, \quad \sqrt[3]{x} = t^2 \end{array} \right| = \int \frac{t^3 6t^5 dt}{t^6 - t^4} = 6 \int \frac{t^8}{t^4(t^2-1)} dt = 6 \int \frac{t^4}{t^2-1} dt = \\ &= 6 \int \frac{(t^2-1)+1}{t^2-1} dt = 6 \int \left(t^2 + 1 + \frac{1}{t^2-1} \right) dt = 2t^3 + 6t + 3 \ln \left| \frac{t-1}{t+1} \right| + C = 2\sqrt{x} + 6\sqrt[6]{x} + 3 \ln \left| \frac{\sqrt[6]{x}-1}{\sqrt[6]{x}+1} \right| + C. \end{aligned}$$

Example 3. Find $\int \frac{xdx}{\sqrt[3]{(x+1)^4} - \sqrt[6]{(x+1)^5}}$.

Solution.

$$\begin{aligned} \int \frac{xdx}{\sqrt[3]{(x+1)^4} - \sqrt[6]{(x+1)^5}} &= \left| \begin{array}{l} x+1 = t^6, \quad dx = 6t^5 dt \\ \sqrt[6]{x+1} = t, \quad \sqrt[3]{x+1} = t^2 \end{array} \right| = \int \frac{(t^6-1)6t^5 dt}{t^8 - t^5} = 6 \int \frac{(t^6-1)t^5 dt}{t^5(t^3-1)} = \\ &= 6 \int (t^3 + 1) dt = 6 \left(\frac{t^4}{4} + t \right) + C = \frac{3}{2} \sqrt[3]{(x+1)^2} + 6 \sqrt[6]{x+1} + C. \end{aligned}$$

Example 4. Find $\int \frac{x^3 dx}{\sqrt{2-x^2}}$.

Solution. We must use trigonometric substitution $x = \sqrt{2} \sin t$.

$$\int \frac{x^3 dx}{\sqrt{2-x^2}} = \left. \begin{array}{l} x = \sqrt{2} \sin t, \\ dx = \sqrt{2} \cos t dt, \\ \sqrt{2-x^2} = \sqrt{2} \cos t \end{array} \right| = \int \frac{(\sqrt{2})^3 \sin^3 t \cdot \sqrt{2} \cos t}{\sqrt{2} \cos t} dt = 2\sqrt{2} \int \sin^3 t dt =$$

$$= -2\sqrt{2} \int (1 - \cos^2 t) d(\cos t) = -2\sqrt{2} \left(\cos t + \frac{\cos^3 t}{3} \right) + C = -2\sqrt{2-x^2} + \frac{\sqrt{(2-x^2)^3}}{3} + C.$$

Exercise Set 10

Evaluate the integral

1. $\int \frac{1 + \sqrt[4]{x}}{1 + \sqrt{x}} dx.$

2. $\int \frac{dx}{\sqrt{4x-1} - \sqrt[4]{4x-1}}.$

3. $\int \frac{\sqrt{x} dx}{\sqrt[3]{x^2 - 4\sqrt{x}}}.$

4. $\int \frac{dx}{x^2 \sqrt{x^2 - 1}}.$

5. $\int x^3 \sqrt{9 - x^2} dx.$

6. $\int \sqrt{\frac{1-x}{1+x}} \frac{dx}{x}.$

7. $\int \frac{\sqrt{1-x^2}}{x} dx.$

8. $\int \frac{\sqrt{x^2 + 4}}{x^2} dx.$

9. $\int x^5 \cdot \sqrt[3]{(1+x^3)^2} dx.$

10. $\int x \cdot \sqrt{4-x^2} dx.$

11. $\int \frac{\sqrt{1-x^2}}{x^2} dx.$

12. $\int \sqrt{25-x^2} dx.$

2.4 Areas and Distances

In this section we discover that in trying to find the area under a curve or the distance traveled by a car, we end up with the same special type of limit. We begin by attempting to solve the *area problem*: find the area of the region that lies under the curve $y = f(x)$ from a to b . This means that, illustrated in Figure 2, is bounded by the graph of a continuous function f [where $f(x) \geq 0$], the vertical lines $x = a$ and $x = b$, and the x -axis.

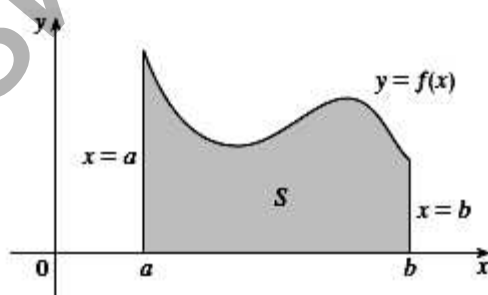

Figure 2

However, it isn't so easy to find the area of a region with curved sides. We all have an intuitive idea of what the area of a region is. But part of the area problem is to make this intuitive idea precise by giving an exact definition of area.

Recall that in defining a tangent we first approximated the slope of the tangent line by slopes of secant lines and then we took the limit of these approximations. We pursue a similar idea for areas. We first approximate the region by rectangles and then we take the limit of the areas of these rectangles as we increase the number of rectangles (Figure 3).

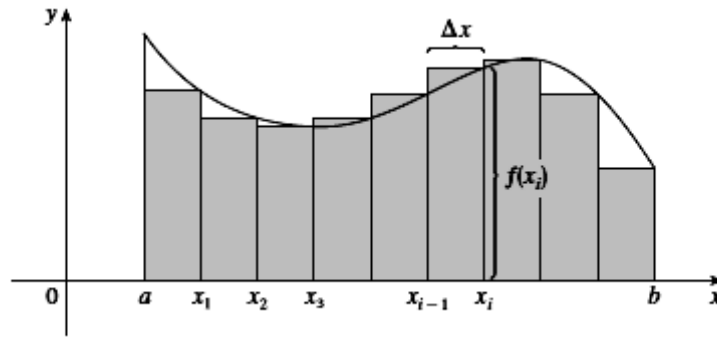

Figure 3

The width of the interval $[a, b]$ is $b - a$, so the width of each of the n strips is $\Delta x = \frac{b - a}{n}$. These strips divide the interval $[a, b]$ into n subintervals $[a, x_1], [x_1, x_2], [x_2, x_3], \dots, [x_{n-1}, b]$. Let's approximate the i -th strip by S_i a rectangle with width Δx and height $f(x_i)$, which is the value of f at the right endpoint (see Figure 3). Then the area of the rectangle is $f(x_i)\Delta x$. What we think of intuitively as the area of S is approximated by the sum of the areas of these rectangles, which is

$$R_n = f(x_1)\Delta x + f(x_2)\Delta x + \dots + f(x_n)\Delta x.$$

Definition. The **area** A of the region S that lies under the graph of the continuous function f is the limit of the sum of the areas of approximating rectangles:

$$A = \lim_{n \rightarrow \infty} R_n = \lim_{n \rightarrow \infty} \sum_{i=1}^n f(x_i)\Delta x.$$

It can be proved that the limit in definition always exists, since we are assuming that $f(x)$ is continuous.

2.5 The Definite Integral

We saw in Section 2. that a limit of the form

$$\lim_{n \rightarrow \infty} R_n = \lim_{n \rightarrow \infty} \sum_{i=1}^n f(x_i)\Delta x \quad (1)$$

arises when we compute an area. It turns out that this same type of limit occurs in a wide variety of situations even when f is not necessarily a positive function. We therefore give this type of limit a special name and notation.

Definition of a Definite Integral. If $f(x)$ is a function defined for $a \leq x \leq b$, we divide the interval $[a, b]$ into n subintervals of equal width $\Delta x = \frac{b - a}{n}$. We let $a = x_0, x_1, x_2, \dots, x_n = b$ be the endpoints of these subintervals and we let $x_1^*, x_2^*, \dots, x_n^*$ be any **sample points** in these subintervals, so x_i^* lies in the i th subinterval $[x_{i-1}, x_i]$. Then the **definite integral of f from a to b** is

$$\int_a^b f(x)dx = \lim_{n \rightarrow \infty} \sum_{i=1}^n f(x_i^*)\Delta x$$

provided that this limit exists. If it does exist, we say that f is **integrable** on $[a, b]$.

Note 1. The symbol \int was introduced by Leibniz and is called an **integral sign**. It is elongated and was chosen because an integral is a limit of sums. In the notation $\int_a^b f(x)dx$ $f(x)$ is called the **integrand** and a and b are called the **limits of integration**; a is the **lower limit** and b is the **upper limit**. For now, the symbol dx has no meaning by itself; $\int_a^b f(x)dx$ is all one symbol. The dx simply indicates that the independent variable is x . The procedure of calculating an integral is called **integration**.

Note 2. The definite integral $\int_a^b f(x)dx$ is a number; it does not depend on x . In fact, we could use any letter in place of x without changing the value of the integral:

$$\int_a^b f(x)dx = \int_a^b f(t)dt = \int_a^b f(u)du.$$

Note 3. The sum

$$\sum_{i=1}^n f(x_i^*) \Delta x_i$$

that occurs in last Definition is called a **Riemann sum** after the German mathematician Bernhard Riemann (1826–1866). So last Definition says, that the definite integral of an integrable function can be approximated to within any desired degree of accuracy by a Riemann sum.

Theorem. If $f(x)$ is continuous on $[a,b]$, or if $f(x)$ has only a finite number of jump discontinuities, then $f(x)$ is integrable on $[a,b]$; that is, the definite integral $\int_a^b f(x)dx$ exists.

Properties of the Integral

$$1. \int_a^b f(x)dx = -\int_b^a f(x)dx.$$

$$2. \int_a^a f(x)dx = 0.$$

$$3. \int_a^b f(x)dx = \int_a^c f(x)dx + \int_c^b f(x)dx.$$

$$4. \int_a^b (f_1(x) \pm f_2(x))dx = \int_a^b f_1(x)dx \pm \int_a^b f_2(x)dx.$$

$$5. \int_a^b cf(x)dx = c \int_a^b f(x)dx, c = \text{const.}$$

$$6. \text{ If } f(x) \geq 0 \text{ (} f(x) \leq 0 \text{) on } [a, b], \text{ then } \int_a^b f(x)dx \geq 0 \text{ (} \int_a^b f(x)dx \leq 0 \text{)}.$$

$$7. \text{ If } f(x) \geq f(x) \text{ } x \in [a, b] \text{ } a < b, \text{ then } \int_a^b f(x)dx \geq \int_a^b f(x)dx.$$

$$8. \text{ If } m \leq f(x) \leq M, \text{ then } m(b-a) \leq \int_a^b f(x)dx \leq M(b-a).$$

The Fundamental Theorem of Calculus (Newton and Leibniz Theorem).

Suppose $f(x)$ is continuous on $[a, b]$.

$$1. \text{ If } F(x) = \int_a^x f(t)dt, \text{ then } F'(x) = f(x).$$

$$2. \int_a^b f(x)dx = F(b) - F(a), \text{ where } F(x) \text{ is any antiderivative of } f(x), \text{ that is, } F'(x) = f(x).$$

The Fundamental Theorem of Calculus says that differentiation and integration are inverse processes. Each undoes what the other does. The Fundamental Theorem of Calculus is unquestionably the most important theorem in calculus and, indeed, it ranks as one of the great accomplishments of the human mind. Before it was discovered, from the time of Eudoxus and Archimedes to the time of Galileo and Fermat, problems of finding areas, volumes, and lengths of curves were so difficult that only a genius could meet the challenge. But now, armed with the systematic method that Newton and Leibniz fashioned out of the Fundamental Theorem, we will see in the chapters to come that these challenging problems are accessible to all of us.

2.6 Rules of the Calculation of the Definite Integral

1. *Formula of Newton – Leibniz.* If $f(x)$ is continuous on $[a, b]$

$$\int_a^b f(x)dx = F(b) - F(a).$$

2. *Replacement of variable in the definite integral.* If $f(x)$ is continuous on $[a, b]$, the function $x = j(t)$ it is differentiated in the section $[a, b]$, and $t \in [a, b]$, $f(t) \in [a, b]$, $f(a) = a$, $f(b) = b$, then

$$\int_a^b f(x)dx = \int_a^b f(f(t))f'(t)dt.$$

3. Evaluate definite integrals by parts

$$\int_a^b u(x)dv(x) = u(x)v(x)\Big|_a^b - \int_a^b v(x)du(x).$$

4. $\int_{-a}^a f(x)dx = 0$, if $f(-x) = -f(x)$;

$$\int_{-a}^a f(x)dx = 2 \int_0^a f(x)dx, \text{ if } f(-x) = f(x).$$

Example 1. Calculate $\int_1^8 (\sqrt[3]{x} - 1)dx$.

Solution. Using the formula of Newton – Leibniz for this integral, however, we have

$$\int_1^8 (\sqrt[3]{x} - 1)dx = \int_1^8 (x^{\frac{1}{3}} - 1)dx = \left(\frac{3}{4}x^{\frac{4}{3}} - x\right)\Big|_1^8 = \left(\frac{3}{4} \cdot 2^4 - 8\right) - \left(\frac{3}{4} - 1\right) = 12 - 8 - 0.75 + 1 = 4,25.$$

Example 2. Calculate $\int_{\frac{\sqrt{2}}{2}}^{\frac{\sqrt{3}}{2}} \frac{\sqrt{1-x^2}}{x^2} dx$.

Solution.

$$\begin{aligned} \int_{\frac{\sqrt{2}}{2}}^{\frac{\sqrt{3}}{2}} \frac{\sqrt{1-x^2}}{x^2} dx &= \left| \begin{array}{l} x = \sin t, \quad dx = \cos t dt \\ x = \frac{\sqrt{2}}{2}, t = \frac{\pi}{4}, \quad x = \frac{\sqrt{3}}{2}, t = \frac{\pi}{3} \end{array} \right| = \int_{\frac{\pi}{4}}^{\frac{\pi}{3}} \frac{\cos^2 t dt}{\sin^2 t} = \int_{\frac{\pi}{4}}^{\frac{\pi}{3}} \frac{1 - \sin^2 t}{\sin^2 t} dt = \\ &= (-\operatorname{ctg} t - t) \Big|_{\frac{\pi}{4}}^{\frac{\pi}{3}} = -\left(\operatorname{ctg} \frac{\pi}{3} + \frac{\pi}{3}\right) + \left(\operatorname{ctg} \frac{\pi}{4} + \frac{\pi}{4}\right) = -\left(\frac{1}{\sqrt{3}} + \frac{\pi}{3}\right) + \left(1 + \frac{\pi}{4}\right) = \\ &= 1 - \frac{\pi}{12} - \frac{1}{\sqrt{3}} \approx 0,161. \end{aligned}$$

Example 3. Calculate $I = \int_e^{e^2} x \ln x dx$.

Solution. Using the formula for integration by parts we get

$$I = \left| \begin{array}{l} u = \ln x, \quad du = \frac{dx}{x} \\ dv = x dx, \quad v = \frac{x^2}{2} \end{array} \right| = \left(\frac{x^2}{2} \ln x \right) \Big|_e^{e^2} - \int_e^{e^2} \frac{x^2 dx}{2x} = \frac{e^4}{2} \cdot 2 - \frac{e^2}{2} - \frac{x^2}{4} \Big|_e^{e^2} = e^4 - \frac{e^2}{2} - \frac{e^4}{4} + \frac{e^2}{4} =$$

$$= \frac{1}{4}(3e^4 - e^2) \approx 39,10.$$

Example 4. Calculate $\int_0^5 \frac{dx}{2 + \sqrt{3x+1}}$.

Solution.

$$\int_0^5 \frac{dx}{2 + \sqrt{3x+1}} = \left| \begin{array}{l} \sqrt{3x+1} = t, \quad x=0 \Rightarrow t=1 \\ x = \frac{1}{3}(t^2 - 1), \quad x=5 \Rightarrow t=4 \\ dx = \frac{2}{3}t dt \end{array} \right| = \int_1^4 \frac{\frac{2}{3}t}{2+t} dt =$$

$$= \frac{2}{3} \int_1^4 \frac{t dt}{t+2} = \frac{2}{3} \int_1^4 \frac{t+2-2}{t+2} dt = \frac{2}{3} \int_1^4 \left(1 - \frac{2}{t+2} \right) dt = \frac{2}{3} t \Big|_1^4 + \frac{4}{3} \ln|t+2| \Big|_1^4 =$$

$$= \frac{8}{3} - \frac{2}{3} + \frac{4}{3} \ln 6 - \frac{4}{3} \ln 3 = 2 + \frac{4}{3} \ln 2 \approx 2,924.$$

Exercise Set 11

Calculate

1. $\int_1^2 \left(2x^2 + \frac{2}{x^4} \right) dx.$

2. $\int_1^{e^2} \frac{dx}{x\sqrt{1+\ln x}}.$

3. $\int_0^{\ln 2} \frac{dx}{e^x \sqrt{1-e^{-2x}}}.$

4. $\int_2^3 \frac{dx}{\sqrt{4x-3-x^2}}.$

5. $\int_{-p/2}^{p/2} \sqrt{\cos x - \cos^3 x} dx.$

6. $\int_3^4 \frac{x^2 - x + 2}{x^4 - 5x^2 + 4} dx.$

7. $\int_0^1 \frac{2x-3}{x^2-2x+5} dx.$

8. $\int_1^5 \frac{dx}{x + \sqrt{2x-1}}.$

9. $\int_0^1 \frac{dx}{x^2 + 4x + 8}.$

10. $\int_2^3 \frac{(x+2)dx}{x^2(x-1)}.$

11. $\int_0^p (x+2) \cos 3x dx.$

2.7 Improper Integrals

In defining a definite integral $\int_a^b f(x)dx$ we dealt with a function f defined on a finite interval

$[a,b]$ and we assumed it does not have an infinite discontinuity. In this section we extend the concept of a definite integral to the case where the interval is infinite and also to the case where f has an infinite discontinuity in $[a,b]$. In either case the integral is called an *improper* integral.

2.7.1 Type 1: Infinite Intervals

Definition of an Improper Integral of Type 1.

(a) If $\int_a^t f(x)dx$ exists for every number $t \geq a$, then

$$\int_a^{+\infty} f(x)dx = \lim_{t \rightarrow +\infty} \int_a^t f(x)dx, \quad (1)$$

provided this limit exists (as a finite number).

(b) If $\int_t^b f(x)dx$ exists for every number $t \leq b$, then

$$\int_{-\infty}^b f(x)dx = \lim_{t \rightarrow -\infty} \int_t^b f(x)dx, \quad (2)$$

provided this limit exists (as a finite number).

The improper integrals $\int_a^{+\infty} f(x)dx$ and $\int_{-\infty}^b f(x)dx$ are called convergent if the corresponding limit exists and divergent if the limit does not exist.

(c) If both $\int_a^{+\infty} f(x)dx$ and $\int_{-\infty}^a f(x)dx$ are convergent, then we define

$$\int_{-\infty}^{+\infty} f(x)dx = \int_{-\infty}^a f(x)dx + \int_a^{+\infty} f(x)dx = \lim_{t \rightarrow -\infty} \int_t^a f(x)dx + \lim_{t \rightarrow +\infty} \int_a^t f(x)dx, \quad (3)$$

In part (c) any real number can be used.

Any of the improper integrals in Definition 1 can be interpreted as an area provided that f is a positive function. For instance, in case (a) if $f(x) \geq 0$ and the integral $\int_a^{+\infty} f(x)dx$ is convergent, then we define the area of the region in $S = \{(x,y) \mid x \geq a, 0 \leq y \leq f(x)\}$ Figure 4 to be

$$A(S) = \int_a^{+\infty} f(x) dx$$

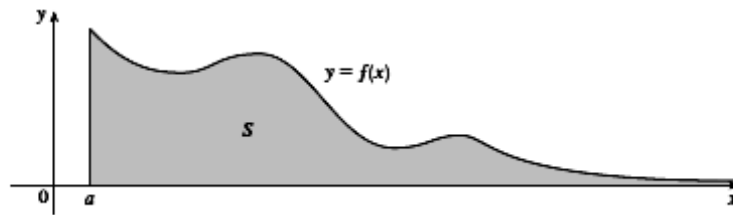

Figure 4

Example 1. Evaluate $\int_0^{+\infty} xe^{-x^2} dx$.

Solution.

$$\begin{aligned} \int_0^{+\infty} xe^{-x^2} dx &= -\frac{1}{2} \int_0^{+\infty} e^{-x^2} d(-x^2) = -\frac{1}{2} \lim_{b \rightarrow +\infty} \int_0^b e^{-x^2} d(-x^2) = -\frac{1}{2} \lim_{b \rightarrow +\infty} (e^{-x^2}) \Big|_0^b = \\ &= -\frac{1}{2} \lim_{b \rightarrow +\infty} \frac{1}{e^{b^2}} + \frac{1}{2} e^0 = \frac{1}{2}. \end{aligned}$$

Example 2. Evaluate $\int_1^{\infty} \frac{2}{x \cdot (9 + \ln^2 x)} dx$.

Solution.

$$\begin{aligned} \int_1^{\infty} \frac{2}{x \cdot (9 + \ln^2 x)} dx &= \lim_{b \rightarrow +\infty} \int_1^b \frac{2}{x \cdot (9 + \ln^2 x)} dx = \lim_{b \rightarrow +\infty} \int_1^b \frac{2 d(\ln x)}{9 + \ln^2 x} = \\ &= \lim_{b \rightarrow +\infty} 2 \cdot \frac{1}{3} \operatorname{arctg}(\ln|x|) \Big|_1^b = \frac{2}{3} \cdot \lim_{b \rightarrow +\infty} (\operatorname{arctg}(\ln b) - \operatorname{arctg}(\ln 1)) = \frac{2}{3} \cdot \frac{\pi}{2} = \frac{\pi}{3}. \end{aligned}$$

2.7.2 Type 2: Discontinuous Integrands

Definition of an Improper Integral of Type 2.

(a) If f is continuous on $[a, b)$ and is discontinuous at b , then

$$\int_a^b f(x) dx = \lim_{\epsilon \rightarrow 0} \int_a^{b-\epsilon} f(x) dx \quad (4)$$

if this limit exists (as a finite number).

(b) If f is continuous on $(a, b]$ and is discontinuous at a , then

$$\int_a^b f(x) dx = \lim_{d \rightarrow 0} \int_{a+d}^b f(x) dx \quad (5)$$

if this limit exists (as a finite number).

The improper integral $\int_a^b f(x)dx$ is called **convergent** if the corresponding limit exists and **divergent** if the limit does not exist.

(c) If f has a discontinuity at c , where $a \leq c \leq b$, and both $\int_a^c f(x)dx$ and $\int_c^b f(x)dx$ are convergent, then we define

$$\int_a^b f(x)dx = \int_a^c f(x)dx + \int_c^b f(x)dx = \lim_{e \rightarrow 0} \int_a^{c-e} f(x)dx + \lim_{d \rightarrow 0} \int_{c+d}^b f(x)dx. \quad (6)$$

Parts (a), (b) and (c) of Definition are illustrated in Figure 5 for the case where $f(x) \geq 0$ and has vertical asymptotes at a , b and c respectively.

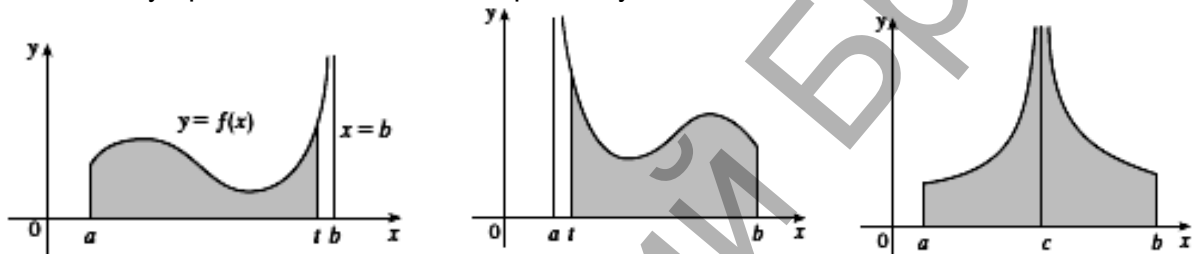

Figure 5

Example 3. Evaluate $\int_0^2 \frac{dx}{\sqrt{2-x}}$.

Solution.

$$\int_0^2 \frac{dx}{\sqrt{2-x}} = -\lim_{e \rightarrow 0} \int_0^{2-e} (2-x)^{-\frac{1}{2}} d(2-x) = -\lim_{e \rightarrow 0} 2\sqrt{2-x} \Big|_0^{2-e} = -2 \lim_{e \rightarrow 0} \sqrt{e} + 2\sqrt{2} = 2\sqrt{2}.$$

Example 4. Evaluate $\int_1^4 \frac{dx}{x^2 - 6x + 9}$.

Solution.

$$\int_1^4 \frac{dx}{x^2 - 6x + 9} = \int_1^4 \frac{dx}{(x-3)^2} = \int_1^3 \frac{dx}{(x-3)^2} + \int_3^4 \frac{dx}{(x-3)^2};$$

$$\lim_{a \rightarrow +0} \int_1^{3-a} \frac{dx}{(x-3)^2} = -\lim_{a \rightarrow +0} \frac{1}{x-3} \Big|_1^{3-a} = -\lim_{a \rightarrow +0} \left(\frac{1}{3-a-3} - \frac{1}{1-3} \right) =$$

$$= -\lim_{a \rightarrow +0} \left(\frac{1}{-a} - \frac{1}{-2} \right) = \lim_{a \rightarrow +0} \left(\frac{1}{a} \right) - \frac{1}{2} = +\infty - \frac{1}{2} = +\infty;$$

$$\begin{aligned} \lim_{b \rightarrow +0} \int_{3+b}^4 \frac{dx}{(x-3)^2} &= - \lim_{b \rightarrow +0} \frac{1}{x-3} \Big|_{3+b}^4 = - \lim_{b \rightarrow +0} \left(\frac{1}{4-3} - \frac{1}{3+b-3} \right) = \\ &= - \lim_{b \rightarrow +0} \left(1 - \frac{1}{+b} \right) = -1 + \lim_{b \rightarrow +0} \left(\frac{1}{b} \right) = -1 + \infty = +\infty. \end{aligned}$$

Improper integral divergent, since limits are equal to infinity.

2.7.3 A Comparison Test for Improper Integrals

Sometimes it is impossible to find the exact value of an improper integral and yet it is important to know whether it is convergent or divergent. In such cases the following theorem is useful. Although we state it for Type 1 integrals, a similar theorem is true for Type 2 integrals.

Comparison Theorem. Suppose that f and g are continuous functions with $f(x) \geq g(x) \geq 0$ for $x \geq a$.

(a) If $\int_a^{+\infty} f(x)dx$ is convergent, then $\int_a^{+\infty} g(x)dx$ is convergent.

(b) If $\int_a^{+\infty} g(x)dx$ is divergent, then $\int_a^{+\infty} f(x)dx$ is divergent.

We omit the proof of the Comparison Theorem, but Figure 6 makes it seem plausible.

If the area under the top curve $y = f(x)$ is finite, then so is the area under the bottom curve $y = g(x)$. And, if the area under $y = g(x)$ is infinite, then so is the area under $y = f(x)$.

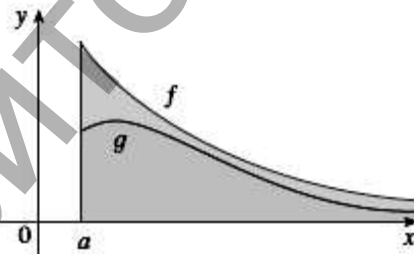

Figure 6

Example 4. Evaluate $\int_1^{+\infty} \frac{2 + \sin x}{\sqrt{x}} dx$.

Solution. Let us estimate integrand for all x from the space of integration, we will obtain the inequality

$$\frac{1}{\sqrt{x}} \leq \frac{2 + \sin x}{\sqrt{x}} \leq \frac{3}{\sqrt{x}}.$$

$$\int_1^{\infty} \frac{dx}{\sqrt{x}} = \lim_{b \rightarrow \infty} \int_1^b \frac{dx}{\sqrt{x}} = 2 \lim_{b \rightarrow \infty} \sqrt{x} \Big|_1^b = 2 \lim_{b \rightarrow \infty} \sqrt{b} - 2 = \infty.$$

This means that this integral is divergent.

Exercise Set 12

Evaluate

$$1. \int_1^{\infty} \frac{dx}{x^2(x+1)},$$

$$2. \int_{-\infty}^{\infty} \frac{dx}{x^2+2x+2},$$

$$3. \int_1^4 \frac{x dx}{\sqrt{x-1}},$$

$$4. \int_{-1}^1 \frac{3x^2+2}{\sqrt[3]{x^2}} dx,$$

$$5. \int_0^1 \frac{dx}{x^3-6x^2},$$

$$6. \int_3^{+\infty} \frac{dx}{x^3-4x^2},$$

$$7. \int_0^{2.5} \frac{dx}{x^2-5x+6},$$

$$8. \int_p^{+\infty} \sin x dx.$$

2.8 Applications of Integration

In this chapter we explore some of the applications of the definite integral by using it to compute areas between curves, volumes of solids, and the work done by a varying force. The common theme is the following general method, which is similar to the one we used to find areas under curves: We break up a quantity Q into a large number of small parts. We next approximate each small part by a quantity of the form $f(x_i^*)\Delta x_i$ and thus approximate Q by a Riemann sum. Then we take the limit and express Q as an integral. Finally we evaluate the integral using the Fundamental Theorem of Calculus.

2.8.1 Areas Between Curves

Here we use integrals to find areas of regions that lie between the graphs of two functions. Consider the region S that lies between two curves $y = f(x)$ and $y = g(x)$ and between the vertical lines $x = a$ and $x = b$, where $y = f(x)$ and $y = g(x)$ are continuous functions and $f(x) \geq g(x)$ for all x in $[a, b]$ (See Figure 7)

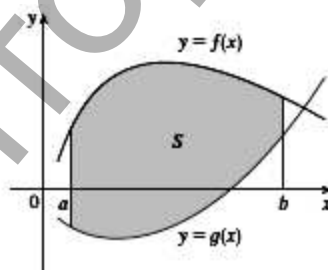

Figure 7

The area A of the region bounded by the curves $y = f(x)$, $y = g(x)$, and the lines $x = a$, $x = b$, where $y = f(x)$ and $y = g(x)$ are continuous and $f(x) \geq g(x)$ for all x in $[a, b]$, is

$$S = \int_a^b (f(x) - g(x)) dx.$$

Note 1. If $y = g(x) = 0$ then $S = \int_a^b f(x) dx$.

Note 2. If we are asked to find the area between the curves $y = f(x)$ and $y = g(x)$ where $f(x) \geq g(x)$ for some values of x but $f(x) \leq g(x)$ for other values of x , then we split the given

region into several regions S_1, S_2, S_3, \dots with areas A_1, A_2, A_3, \dots as shown in Figure 8. We then define the area of the region S to be the sum of the areas of the smaller regions S_1, S_2, S_3, \dots , that is $A = A_1 + A_2 + \dots$

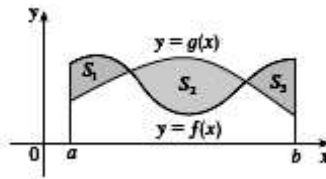

Figure 8

The area between the curves $y = f(x)$ and $y = g(x)$ and between $x = a$ and $x = b$ is

$$S = \int_a^b |f(x) - g(x)| dx.$$

Note 3. If the curve is assigned by the parametric equations $x = x(t), y = y(t)$, the area A of the region bounded by this curve is

$$S = \int_a^b y(t) \cdot x'(t) dt, \text{ where } a = x(a), b = x(b).$$

Note 4. Area of figures in the polar coordinates (See Figure 9 and Figure 10) is

$$S = \frac{1}{2} \int_a^b r^2(\theta) d\theta.$$

$$S = \frac{1}{2} \int_a^b (r_1^2(\theta) - r_2^2(\theta)) d\theta.$$

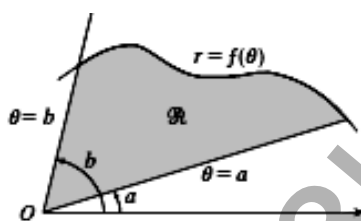

Figure 9

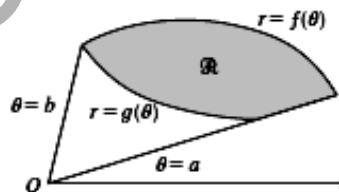

Figure 10

Example 1. Find the area enclosed by the line $g(x) = -x + 1$ and the parabola

$$f(x) = -x^2 + 2x + 5.$$

Solution. By solving the two equations we find that the points of intersection are $(-1; 2)$, $(4; -3)$:

$$\begin{aligned} f(x) &= g(x), \\ -x + 1 &= -x^2 + 2x + 5, \\ x^2 - 3x - 4 &= 0, \\ x_1 &= -1; x_2 = 4, \\ y_1 &= 2; y_2 = -3. \end{aligned}$$

$$\begin{aligned}
\text{Thus } S &= \int_{-1}^4 (f(x) - g(x)) dx = \int_{-1}^4 (-x^2 + 2x + 5 - (-x + 1)) dx = \int_{-1}^4 (-x^2 + 2x + 5 + x - 1) dx = \\
&= \int_{-1}^4 (-x^2 + 3x + 4) dx = \left(-\frac{x^3}{3} + 3 \cdot \frac{x^2}{2} + 4x \right) \Big|_{-1}^4 = \\
&= \left(-\frac{4^3}{3} + 3 \cdot \frac{4^2}{2} + 4 \cdot 4 \right) - \left(-\frac{(-1)^3}{3} + 3 \cdot \frac{(-1)^2}{2} + 4 \cdot (-1) \right) = \\
&= \left(-\frac{64}{3} + 24 + 16 \right) - \left(\frac{1}{3} + \frac{3}{2} - 4 \right) = -\frac{64}{3} + 40 - \frac{1}{3} - \frac{3}{2} + 4 = 44 - \frac{65}{3} - \frac{3}{2} = \\
&= 44 - 21\frac{2}{3} - 1\frac{1}{2} = 22 - \frac{2}{3} - \frac{1}{2} = 22 - \frac{7}{6} = 20\frac{5}{6}.
\end{aligned}$$

Example 2. Find the area enclosed by the curve $\begin{cases} x = 2 \cos^3 t \\ y = 2 \sin^3 t \end{cases}$.

Solution. These equations determine astroid (See Figure 11). Since figure is symmetrical relative to coordinate axes, then let us find area its fourth, which lies at the first quadrant.

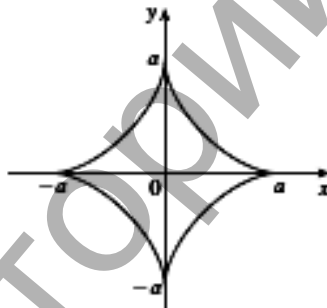

Figure 11

$$x'(t) = 2 \cdot 3 \cdot \cos^2 t \cdot (-\sin t) = -6 \cdot \cos^2 t \cdot \sin t.$$

$$\text{If } x(t_1) = 0 \Rightarrow t_1 = \frac{\pi}{2}; \quad x(t_2) = 2 \Rightarrow t_2 = 0.$$

$$\text{Thus } S = \int_{t_1}^{t_2} y(t) \cdot x'(t) dt:$$

$$S = \int_{\frac{\pi}{2}}^0 2 \sin^3 t \cdot (-6 \cos^2 t \cdot \sin t) dt = 12 \int_0^{\frac{\pi}{2}} \sin^4 t \cdot \cos^2 t dt = 3 \int_0^{\frac{\pi}{2}} \sin^2 2t \cdot \sin^2 t dt =$$

$$= 3 \int_0^{\frac{\pi}{2}} \sin^2 2t \cdot \frac{1 - \cos 2t}{2} dt = \frac{3}{2} \int_0^{\frac{\pi}{2}} \sin^2 2t dt - \frac{3}{2} \int_0^{\frac{\pi}{2}} \sin^2 2t \cdot \cos 2t dt =$$

$$= \frac{3}{2} \int_0^{\frac{p}{2}} \frac{1 - \cos 4t}{2} dt - \frac{3}{4} \int_0^{\frac{p}{2}} \sin^2 2t d(\sin 2t) = \frac{3}{4} t \Big|_0^{\frac{p}{2}} - \frac{3}{16} \sin 4t \Big|_0^{\frac{p}{2}} - \frac{1}{4} \sin^3 2t \Big|_0^{\frac{p}{2}} = \frac{3p}{8}$$

After multiplying the obtained area to 4, we will obtain the area of the entire of the astroid

$$S_{\text{astroid}} = 4 \cdot S = 4 \cdot \frac{3p}{8} = \frac{3p}{2} \approx 4,712$$

2.8.2 Volumes

In trying to find the volume of a solid we face the same type of problem as in finding areas. We have an intuitive idea of what volume means, but we must make this idea precise by using calculus to give an exact definition of volume.

For a solid S that isn't a cylinder we first "cut" S into pieces and approximate each piece by a cylinder. We estimate the volume of S by adding the volumes of the cylinders. We arrive at the exact volume of S through a limiting process in which the number of pieces becomes large.

We start by intersecting S with a plane and obtaining a plane region that is called a **cross-section** of S .

Let $A(x)$ be the area of the cross-section of S in a plane P_x perpendicular to the x -axis and passing through the point x , where $a \leq x \leq b$. (See Figure 12). Think of slicing S with a knife through x and computing the area of this slice.) The cross-sectional area $A(x)$ will vary x as increases from a to b .

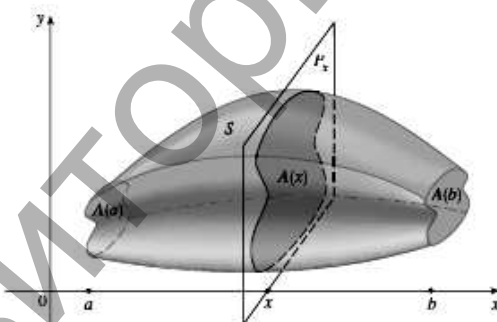

Figure 12

Definition of Volume. Let S be a solid that lies between $x=a$ and $x=b$. If the cross-sectional area of S in the plane P_x , through x and perpendicular to the x -axis, is $A(x)$, where $A(x)$ is a continuous function, then the **volume** of S is

$$V = \int_a^b A(x) dx.$$

Note 1. The volume of the solid in Figure 13, obtained by rotating about the y -axis the region under the curve $y = f(x)$ from a to b , is

$$V_x = p \int_a^b f^2(x) dx \quad (V_y = 2p \int_a^b xf(x) dx).$$

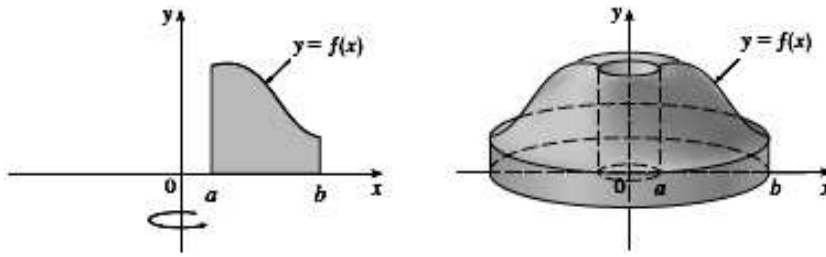

Figure 13

Note 2. If curvilinear sector revolves around the polar axis, then the volume of body of revolution is found by the formula $V = \frac{2}{3}p \int_a^b r^3(j) \cdot \sin j \, dj$.

$$V = \frac{2}{3}p \int_a^b r^3(j) \cdot \sin j \, dj$$

Example 3. Find the volume of the solid obtained by rotating the region bounded by $y = x - x^2$ and $y = 0$ about the line $x = 2$.

Solution. Figure 14 shows the region and a cylindrical shell formed by rotation about the line $x = 2$. It has radius $2 - x$, circumference $2p(2 - x)$, and height $x - x^2$.

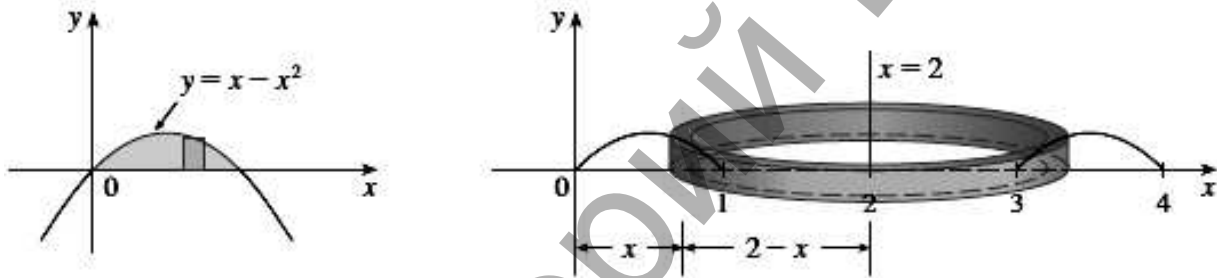

Figure 14

The volume of the given solid is

$$V = \int_0^1 2p(2-x)(x-x^2)dx = 2p \int_0^1 (x^3 - 3x^2 + 2x)dx = 2p \left(\frac{x^4}{4} - x^3 + x^2 \right)_0^1 = \frac{p}{2}$$

2.8.3 Arc Length

What do we mean by the length of a curve? We might think of fitting a piece of string to the curve in Figure 15 and then measuring the string against a ruler. But that might be difficult to do with much accuracy if we have a complicated curve. We need a precise definition for the length of an arc of a curve, in the same spirit as the definitions we developed for the concepts of area and volume.

If the curve is a polygon, we can easily find its length; we just add the lengths of the line segments that form the polygon. (We can use the distance formula to find the distance between the endpoints of each segment.) We are going to define the length of a general curve by first approximating it by a polygon and then taking a limit as the number of segments of the polygon is increased. This process is familiar for the case of a circle, where the circumference is the limit of lengths of inscribed polygons (see Figure16).



Figure 15

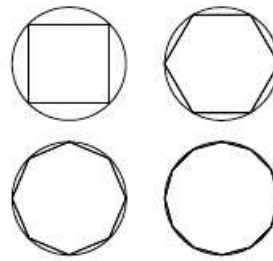

Figure 16

Now suppose that a curve C is defined by the equation $y = f(x)$, where f is continuous and $a \leq x \leq b$. We obtain a polygonal approximation to C by dividing the interval $[a, b]$ into n sub-intervals with endpoints $a = x_0, x_1, x_2, \dots, x_n = b$ and equal width Δx . If $y_i = f(x_i)$, then the point $P_i(x_i; y_i)$ lies on C and the polygon with vertices P_1, P_2, P_3, \dots illustrated in Figure 17, is an approximation to C .

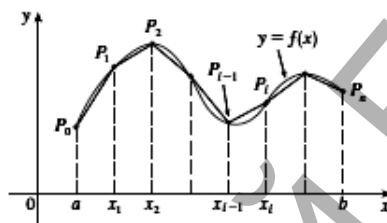

Figure 17

The length L of C is approximately the length of this polygon and the approximation gets better as we let n increase.

The Arc Length Formula. If $y = f(x)$ is continuous on $[a, b]$, then the length of the curve $y = f(x)$, $a \leq x \leq b$ is

$$l = \int_a^b \sqrt{1 + f'^2(x)} dx.$$

Note 1. If a curve has the equation $x = f(y)$, $c \leq y \leq d$, and $x = j(y)$ is continuous, we obtain the following formula for its length:

$$l = \int_c^d \sqrt{1 + f'^2(y)} dy.$$

Note 2. If curve is assigned by the parametric equations $x = x(t), y = y(t), t \in [a, b]$, we obtain the following formula for its length:

$$l = \int_a^b \sqrt{x'^2(t) + y'^2(t)} dt.$$

Note 3. If it is known that the polar equation of arc AB is $r = r(f)$, $f \in [a, b]$, the length of its arc is equal:

$$l = \int_a^b \sqrt{r^2(j) + r'^2(j)} dj .$$

Example 4. Find the arc length function for the curve $\begin{cases} y^2 = (x+1)^3, \\ -1 \leq x \leq 0. \end{cases}$

Solution.

For calculation the arc length of this line we will use the formula: $l = \int_a^b \sqrt{1+(y')^2} dx$.

The line is symmetrical relative to X-axis. Therefore we will search for the length of the line lying at second fourth.

$$y = (x+1)^{\frac{3}{2}}.$$

Let us calculate the derivative $y' = \frac{3}{2}(x+1)^{\frac{1}{2}}$.

$$\text{Then } l = \int_{-1}^0 \sqrt{1 + \left(\frac{3}{2}(x+1)^{\frac{1}{2}}\right)^2} dx = \int_{-1}^0 \sqrt{1 + \frac{9}{4}(x+1)} dx = \frac{1}{2} \cdot \int_{-1}^0 \sqrt{9x+13} dx =$$

$$= \frac{1}{2} \cdot \frac{1}{9} \cdot \frac{(9x+13)^{\frac{3}{2}}}{\frac{3}{2}} \Big|_{-1}^0 = \frac{1}{27} (\sqrt{13^3} - 8) = \frac{13\sqrt{13} - 8}{27}.$$

$$L = 2 \cdot l = 2 \cdot \frac{13\sqrt{13} - 8}{27} = \frac{26\sqrt{13} - 16}{27} \approx 2,879.$$

Example 5. Find the arc length function for the curve $r = 3(1 + \cos j)$.

Solution. Cardioid is a curve symmetrical relative to polar axis. Let us calculate the arc length of that lying on top from the polar axis (See Figure 18).

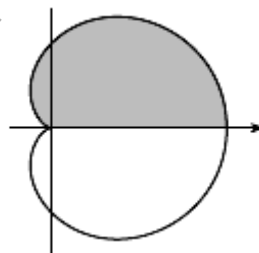

Figure 18

For calculating the arc length of this line we will use the formula

$$l = \int_a^b \sqrt{r^2 + (r')^2} dj.$$

Let us calculate the derivative $r' = -3 \sin j$. Then

$$l = \int_0^p \sqrt{9(1 + \cos j)^2 + 9\sin^2 j} dj = 3 \int_0^p \sqrt{2 + 2\cos j} dj = 6 \int_0^p \cos \frac{j}{2} dj = 12 \sin \frac{j}{2} \Big|_0^p = 12.$$

Consequently, the length of the entire cardioid is equal $L = 2 \cdot l = 2 \cdot 12 = 24$.

2.8.4 Work

The term *work* is used in everyday language to mean the total amount of effort required to perform a task. In physics it has a technical meaning that depends on the idea of a *force*. Intuitively, you can think of a force as describing a push or pull on an object - for example, a horizontal push of a book across a table or the downward pull of the earth's gravity on a ball.

Let under the action of force $F(s)$ the material point move along straight Ox . The work of this force in the section of way $[a, b]$ is determined from the formula

$$A = \int_a^b F(s) ds.$$

Exercise Set 13

To calculate the areas of the figures, limited by the assigned lines:

1. $y^2 = 1 - x$, $x = -3$ 2. $\begin{cases} x = 3 \cos t, \\ y = 5 \sin t. \end{cases}$ 3. $r = a(1 + \cos f)$. 4. $x^4 + y^4 = x^2 + y^2$.

(Answers: 1) $\frac{32}{3}$; 2) $15p$; 3) $1,5pa^2$; 4) $\frac{p}{\sqrt{2}}$.)

5. $y^2 + 8x = 16$, $y^2 - 24x = 48$. 6. $\begin{cases} x = 2 \cos t - \cos 2t, \\ y = 2 \sin t - \sin 2t. \end{cases}$ 7. $r^2 = a^2 \sin 2f$.

(Answers: 5) $\frac{32}{3}\sqrt{6}$; 6) $6pa^2$; 7) $0,5a^2$.)

To find the volume of the body, formed by the rotation of the figure, limited by the assigned lines, around the axis indicated:

8. $y = 4x - x^2$, $y = x$, Ox .

9. $y = x^2$, $4x - y = 0$, Oy .

10. $y = x^3$, $x = 2$, $y = 0$, Ox .

Find the length of the arc of the curve from x_1 to x_2 :

11. $y = \ln(1 - x^2)$, $x_1 = 0$, $x_2 = 0,5$.

12. $x = e^t \cos t$, $y = e^t \sin t$, $t_1 = 0$, $t_2 = \ln p$.

13. $y = \ln \cos x$, $x_1 = 0$, $x_2 = \frac{p}{3}$.

14. $x = a \cos^3 t$, $y = a \sin^3 t$, $t_1 = 0$, $t_2 = 2p$.

15. $y = \frac{2}{3} \sqrt{(x-1)^3}$, $x_1 = 1$, $x_2 = 4$.

16. $y = \sqrt{1-x^2} + \arcsin x$, $x_1 = 0$, $x_2 = \frac{9}{16}$.

Find the exact length of the polar curve

17. $r = 2j$, where $0 \leq j \leq \frac{p}{4}$.

18. $r = 3(1 + \sin j)$.

19. $r = \sqrt{2} e^j$, where $|j| \leq \frac{p}{2}$.

20. $r = 2(1 - \cos j)$.

21. $r = \sin^3 \left(\frac{j}{3} \right)$.

22. $r = 3(1 - \cos j)$.

2.9 Applications to Physics and Engineering

Among the many applications of integral calculus to physics and engineering, we consider one here: centers of mass. As with our previous applications to geometry (areas, volumes, and lengths) and to work, our strategy is to break up the physical quantity into a large number of small parts, approximate each small part, add the results, take the limit, and then evaluate the resulting integral.

Moments and Centers of Mass

Our main objective here is to find the point on which a thin plate of any given shape balances horizontally as in Figure 19. This point is called the **center of mass** (or center of gravity) of the plate.



Figure 19

If we have a system of particles with masses m_1, m_2, \dots, m_n , located at the points x_1, x_2, \dots, x_n on the x -axis, it can be shown similarly that the center of mass of the system is located at

$$\bar{x} = \frac{\sum_{i=1}^n m_i x_i}{\sum_{i=1}^n m_i}. \quad (1)$$

The sum of the individual moments $M = \sum_{i=1}^n m_i x_i$ is called the **moment of the system about the origin**.

Then Equation 1 could be rewritten as $\bar{x}M = M$, which says that if the total mass were considered as being concentrated at the center of mass \bar{x} , then its moment would be the same as the moment of the system.

Now we consider a system of particles with masses m_1, m_2, \dots, m_n , located at the points $(x_1; y_1), (x_2; y_2), \dots, (x_n; y_n)$ in the xy -plane as shown in Figure 20.

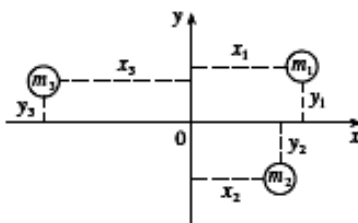

Figure 20

By analogy with the one-dimensional case, we define the **moment of the system about the y-axis** to be

$$M_y = \sum_{i=1}^n m_i x_i$$

and the **moment of the system about the x-axis** as

$$M_x = \sum_{i=1}^n m_i y_i .$$

Then M_y measures the tendency of the system to rotate about the y-axis and M_x measures the tendency to rotate about the x-axis.

As in the one-dimensional case, the coordinates of the center of mass are given in terms of the moments by the formulas

$$\bar{x} = \frac{M_y}{M}, \quad \bar{y} = \frac{M_x}{M}$$

Next we consider a flat plate (called a *lamina*) with uniform density r that occupies a region \mathfrak{R} of the plane. We wish to locate the center of mass of the plate, which is called the **centroid** of \mathfrak{R} . In doing so we use the following physical principles: The **symmetry principle** says that if \mathfrak{R} is symmetric about a line l , then the centroid of \mathfrak{R} lies on l . (If \mathfrak{R} is reflected about l , then \mathfrak{R} remains the same so its centroid remains fixed. But the only fixed points lie on l .) Thus the centroid of a rectangle is its center. Moments should be defined so that if the entire mass of a region is concentrated at the center of mass, then its moments remain unchanged. Also, the moment of the union of two nonoverlapping regions should be the sum of the moments of the individual regions.

Suppose that the region \mathfrak{R} is of the type shown in Figure 21; that is, \mathfrak{R} lies between the lines $x = a$ and $x = b$, above the x-axis, and beneath the graph of f , where f is a continuous function. We divide the interval $[a, b]$ into n subintervals with endpoints $a = x_0, x_1, x_2, \dots, x_n = b$ and equal width Δx . We choose the sample point x_i^* to be the midpoint \bar{x}_i of the i -th subinterval, that is $\bar{x}_i = \frac{x_i + x_{i+1}}{2}$. This determines the polygonal approximation to \mathfrak{R} shown in Figure 22. The centroid of the i -th approximating rectangle R_i is its center $C_i(\bar{x}_i, \frac{1}{2}f(\bar{x}_i))$. Its area is $f(\bar{x}_i)\Delta x_i$, so its mass is $m_i = r f(\bar{x}_i)\Delta x_i$.

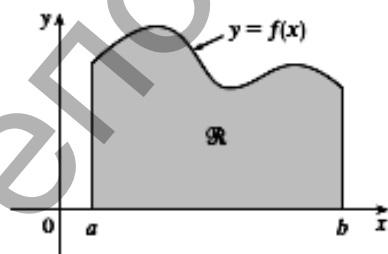

Figure 21

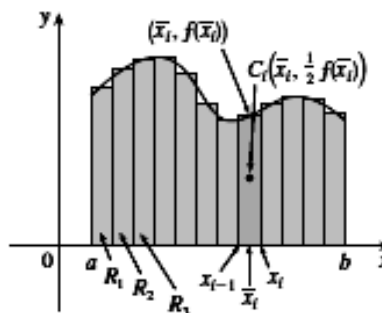

Figure 22

Adding these moments, we obtain the moment of the polygonal approximation to \mathfrak{R} , and then by taking the limit as $n \rightarrow \infty$ we obtain the moment of \mathfrak{R} itself about the y-axis:

$$M_y = r \int_a^b x f(x) dx.$$

Again we add these moments and take the limit to obtain the moment of \mathfrak{R} about the x -axis:

$$M_x = \frac{1}{2}r \int_a^b f^2(x)dx.$$

The mass of the plate is the product of its density and its area $M = r \int_a^b f(x)dx$, and so:

$$\bar{x} = \frac{M_y}{M}, \quad \bar{y} = \frac{M_x}{M}.$$

Note 1. If the plane figure is limited by the lines $y = f_1(x)$, $y = f_2(x)$, $x \in [a, b]$ and $d = d(x)$ -the surface density of figure

$$M = \int_a^b d(x)(f_2(x) - f_1(x))dx,$$

$$M_y = \int_a^b x d(x)(f_2(x) - f_1(x))dx,$$

$$M_x = \frac{1}{2} \int_a^b d(x)(f_2^2(x) - f_1^2(x))dx,$$

$$\bar{x} = \frac{M_y}{M}, \quad \bar{y} = \frac{M_x}{M}.$$

Note 2. The static moments of the material arc, assigned by equation $y = f(x)$, $x \in [a, b]$, relative to coordinate axes are found by the formulas

$$M = \int_a^b r(x) \sqrt{1 + f'^2(x)} dx,$$

$$M_x = \int_a^b r(x) f(x) \sqrt{1 + f'^2(x)} dx,$$

$$M_y = \int_a^b r(x) x \sqrt{1 + f'^2(x)} dx,$$

$$\bar{x} = \frac{M_y}{M}, \quad \bar{y} = \frac{M_x}{M}.$$

Example 1. Find the center of mass of a semicircular plate of radius r .

Solution. We place the semicircle as in Figure 23 so that $f(x) = \sqrt{r^2 - x^2}$ and $a = -r$, $b = r$.

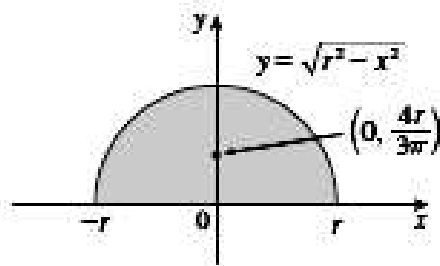

Figure 23

Here there is no need to use the formula to calculate \bar{x} because, by the symmetry principle, the center of mass must lie on the y-axis, so $\bar{x} = 0$. The area of the semicircle is $S = \frac{1}{2}pr^2$, so

$$\bar{y} = \frac{1}{\frac{1}{2}pr^2} \frac{1}{2} \int_{-r}^r (\sqrt{r^2 - x^2})^2 dx = \frac{2}{pr^2} \int_0^r (r^2 - x^2) dx = \frac{2}{pr^2} \left[r^2x - \frac{x^3}{3} \right]_0^r = \frac{2}{pr^2} \frac{2r^3}{3} = \frac{4r}{3p}.$$

The center of mass is located at the point $\left(0; \frac{4r}{3p}\right)$.

Exercise Set 14

Find the coordinates of the center of the masses of flat uniform figure (F) or uniform curve (L):

1. (F) $\begin{cases} y = x^2; \\ y = 3 - x. \end{cases}$

2. (F) $\begin{cases} y^2 = 2x - 2; \\ y = x - 1. \end{cases}$

3. (F) $\begin{cases} x^2 + 4y - 16 = 0; \\ y = 0. \end{cases}$

4. (F) $\begin{cases} y^2 = 4 - x; \\ y = 0. \end{cases}$

5. (F) $\begin{cases} y = x^2 \\ y = \sqrt{x}. \end{cases}$

6. (F) $r = 1 + \cos j$.

Literature

1 Stewart James Calculus Early Transcendental. 2008. pp. 1038.

2 Stein Sh. Calculus and analytic geometry. 1987. pp.1061.

3 Высшая математика. Методические указания и варианты заданий по разделам: Функции нескольких переменных, Интегральное исчисление, Дифференциальные уравнения, Числовые и функциональные ряды / И.И. Гладкий, Л.П. Махнист и [др], УО «Брестский государственный технический университет». – Брест : БрГТУ, 2013. – 40 с.

4 Интегралы. Дифференциальные уравнения: Практикум по дисциплине «Высшая математика» для студентов технических специальностей / И.В. Лизунова, О.К. Денисович, Е.М. Остапчук; УО «Брестский государственный технический университет». – Брест: БрГТУ, 2009. – 84 с.

Contents

I	FUNCTIONS OF SEVERAL VARIABLES.....	3
1.1	Functions of Two Variables.....	3
	<i>Exercise Set 1</i>	5
1.2	Partial Derivatives.....	5
	<i>Exercise Set 2</i>	9
1.3	Differentials. The Chain Rule.....	10
	<i>Exercise Set 3</i>	13
1.4	Higher Derivatives. Maximum and Minimum Values.....	14
	<i>Exercise Set 4</i>	20
II	INTEGRALS.....	21
2.1	Antiderivative.....	21
2.2	Indefinite Integrals.....	23
2.3	Techniques of Integration.....	24
2.3.1	Integration by the introduction of derivative under the sign of differential.....	24
	<i>Exercise Set 5</i>	26
2.3.2	Integration by Parts.....	27
	<i>Exercise Set 6</i>	28
2.3.3	Replacement of Variable in the Indefinite Integral.....	28
	<i>Exercise Set 7</i>	29
2.3.4	Integration of Rational Functions.....	29
	<i>Exercise Set 8</i>	32
2.3.5	Trigonometric Integrals.....	32
	<i>Exercise Set 9</i>	35
2.3.6	Integration of Nonrational Functions.....	35
	<i>Exercise Set 10</i>	37
2.4	Areas and Distances.....	37
2.5	The Definite Integral.....	38
2.6	Rules of the Calculation of the Definite Integral.....	40
	<i>Exercise Set 11</i>	42
2.7	Improper Integrals.....	43
2.7.1	Type 1: Infinite Intervals.....	43
2.7.2	Type 2: Discontinuous Integrands.....	44
2.7.3	A Comparison Test for Improper Integrals.....	46
	<i>Exercise Set 12</i>	47
2.8	Applications of Integration.....	47
2.8.1	Areas Between Curves.....	47
2.8.2	Volumes.....	50
2.8.3	Arc Length.....	51
2.8.4	Work.....	53
	<i>Exercise Set 13</i>	54
2.9	Applications to Physics and Engineering.....	54
	<i>Exercise Set 14</i>	58
	Literature.....	58

УЧЕБНОЕ ИЗДАНИЕ

Составители:

*Гладкий Иван Иванович
Дворниченко Александр Валерьевич
Дерачиц Наталия Александровна
Каримова Татьяна Ивановна
Шишко Татьяна Витальевна*

FUNCTIONS OF SEVERAL VARIABLES INTEGRALS

for foreign first-year students

учебно-методическая разработка на английском языке
по дисциплине «**Математика**»
для студентов 1-го курса

Ответственный за выпуск: А.В. Дворниченко
Редактор: Боровикова Е.А.
Компьютерная верстка: Боровикова Е.А.
Корректор: Шишко Т.В.

Подписано к печати 27.02.2014 г. Формат 60x84 ¹/₁₆. Бумага «Снегурочка».
Усл. п. л. 3.5. Уч.-изд. л. 3.75. Заказ № 126. Тираж 40 экз.
Отпечатано на ризографе Учреждения образования
«Брестский государственный технический университет».
224017, г. Брест, ул. Московская, 267.